

White Rabbit based sub-nsec time synchronization, time stamping and triggering in distributed large scale astroparticle physics experiments

M. Brückner^{1*}, Ralf Wischnewski²
 1-Paul Scherrer Institut, Villigen, Switzerland
 2-DESY, Zeuthen, Germany

* martin.brueckner@psi.ch

Wir schaffen Wissen – heute für morgen



Time-Synchronization to sub-nsec precision between detector subsystems in large scale astroparticle physics experiments can efficiently be provided by White-Rabbit (WR) [1], a new Ethernet-based technology for time and frequency transfer. We discuss principles and advantages of WR for distributed detector arrays, which allows clock-synchronization and trigger timestamping at sub-nanosecond precision; as well as for complex and flexible topological trigger strategies, based on Ethernet-routed timestamps. We describe a White-Rabbit implementation at the Gamma-Ray facility HiSCORE (Siberia) for air shower reconstruction; and first experience with the next generation Zynq-based WR-ZEN platform.

WR+Timestamp firmware for Astroparticle Experiments

SPEC board with modified design

- Intended to be used as PCIe card inside a PC
- Modified design timestamps with a resolution of 1ns
- 5Ch DIO has adjustable input thresholds
- In standalone mode limited network/software capabilities due to the softcore lm32 cpu
- Time stamp read out rate at 1kHz

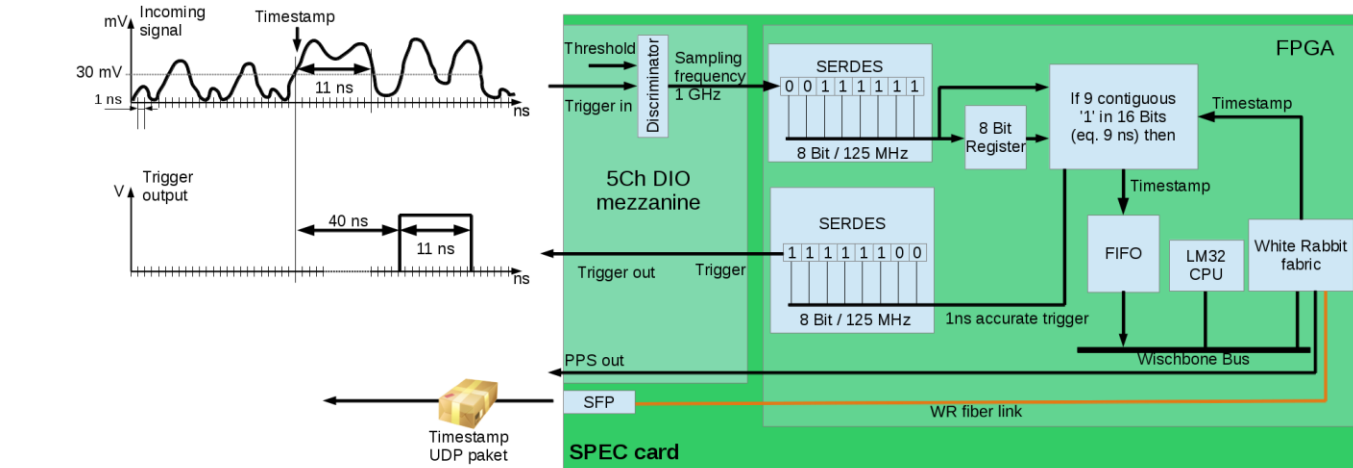

Modified SPEC firmware using the 5 Ch DIO card and the in-FPGA SerDes blocks. Timestamps were written into a FIFO read out by the LM32 CPU.

ZEN board (Zynq based) by 7Sols

- Intended to be used as standalone device
- White Rabbit Core running in Programmable Logic
- Linux has access to the White Rabbit core register over the AXI bus (e.g. monitoring)
- Linux can read out the time stamp FIFO
- WR link can be used as network interface for sending/receiving network packages
- Timestamp resolution depends on Zynq Speed Grade: 2ns (-1) and 1ns (-3)
- High time stamp read out rate of >100 kHz

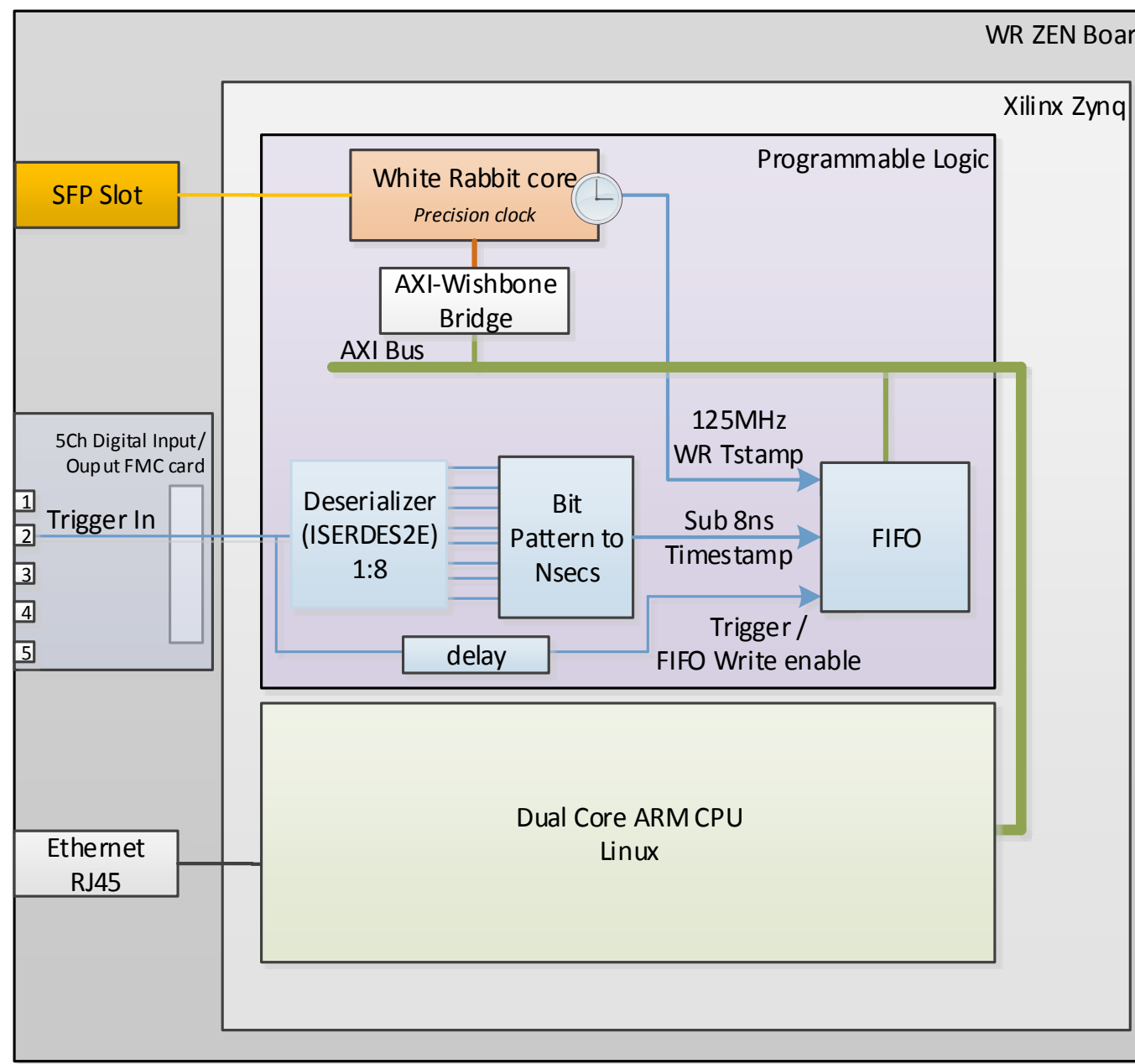

Modified ZEN firmware using the 5 Ch DIO card and the in-FPGA SerDes blocks. Timestamps were written into a FIFO read out by the ARM CPU (Linux)

With this firmware / hardware

- WR stable 125MHz clock
- WR trigger input and output
- WR time stamps
- With ZEN local distributed trigger decisions possible
- Or global array trigger decision over WR link

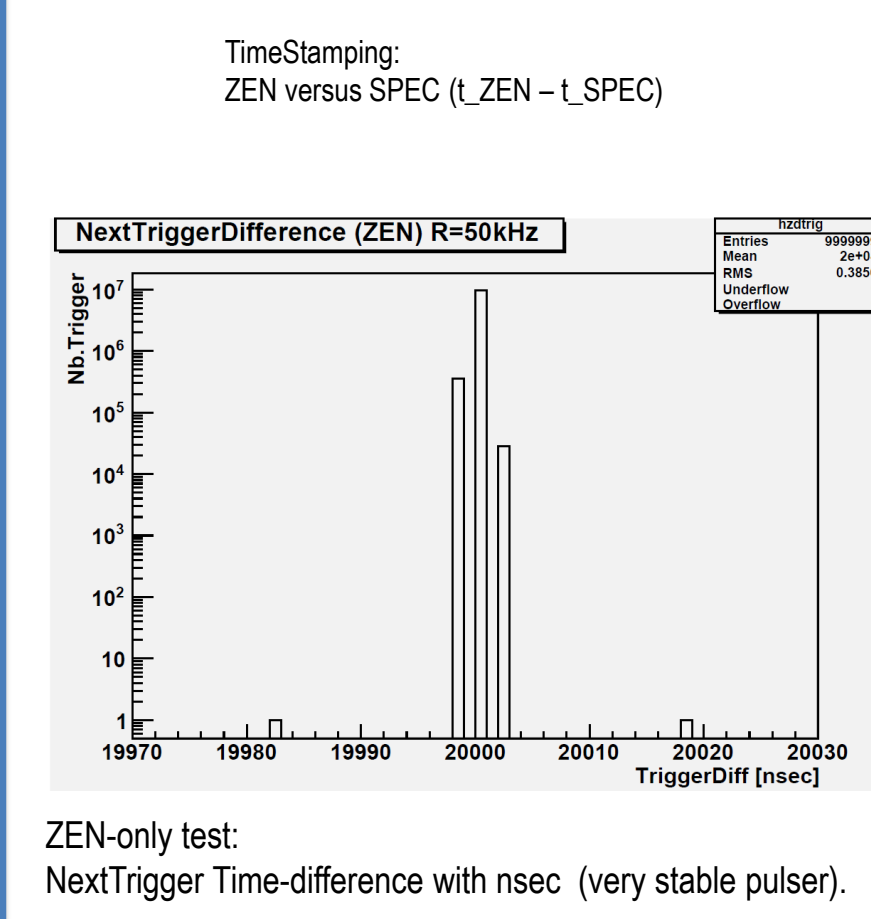
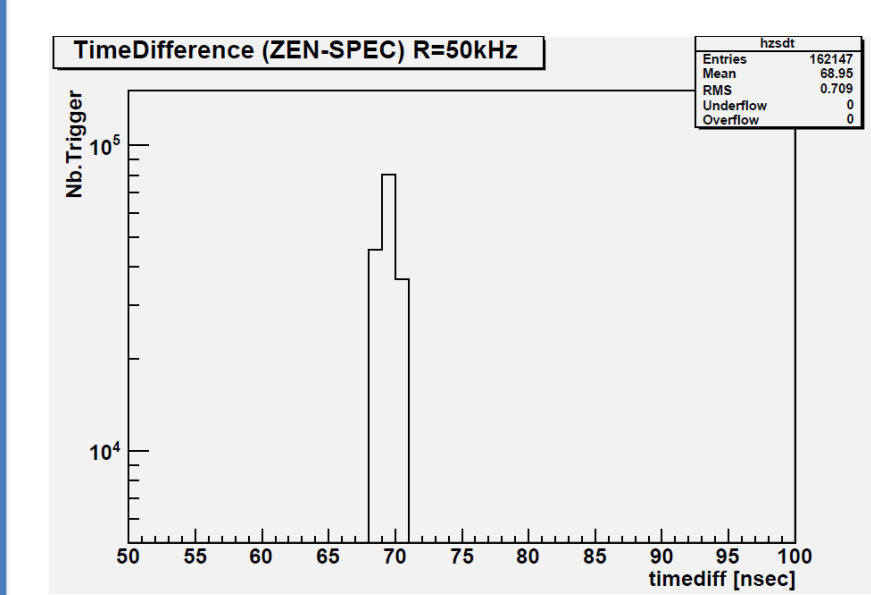

ZEN-only test: NextTrigger Time-difference with nsec (very stable pulser).



Future Work

- Make use of the SerDes oversampling mode for sub-nsec (< 500ps) time stamp resolution
- Implementing local distributed triggering

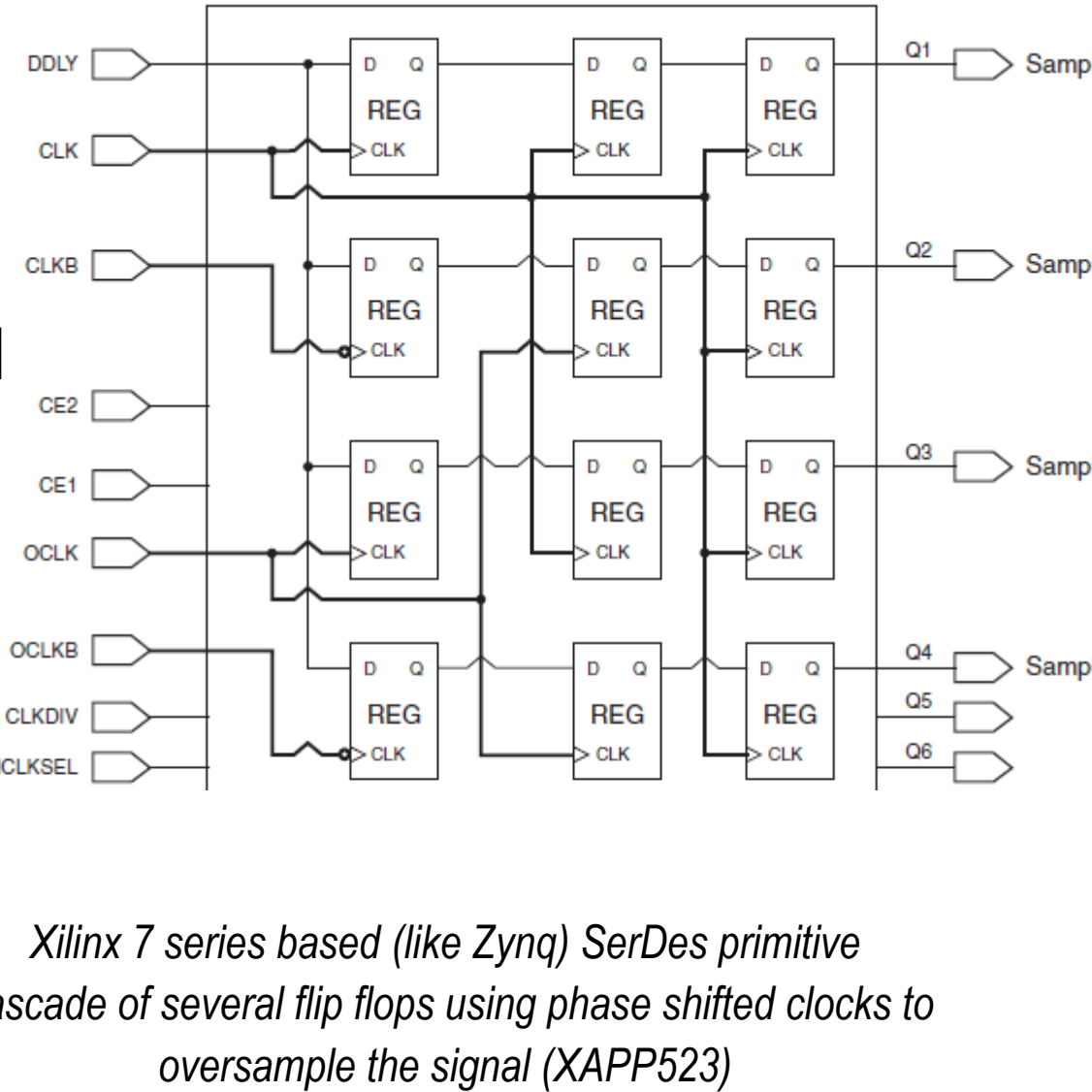

Xilinx 7 series based (like Zynq) SerDes primitive Cascade of several flip flops using phase shifted clocks to oversample the signal (XAPP523)

White Rabbit [1]

- Fully deterministic Ethernet-based network for data transfer and synchronization
- Subnanosecond accuracy
- Open Source Hard-, Firm-, and Software
- Developed at CERN
- Standard GbE compatible

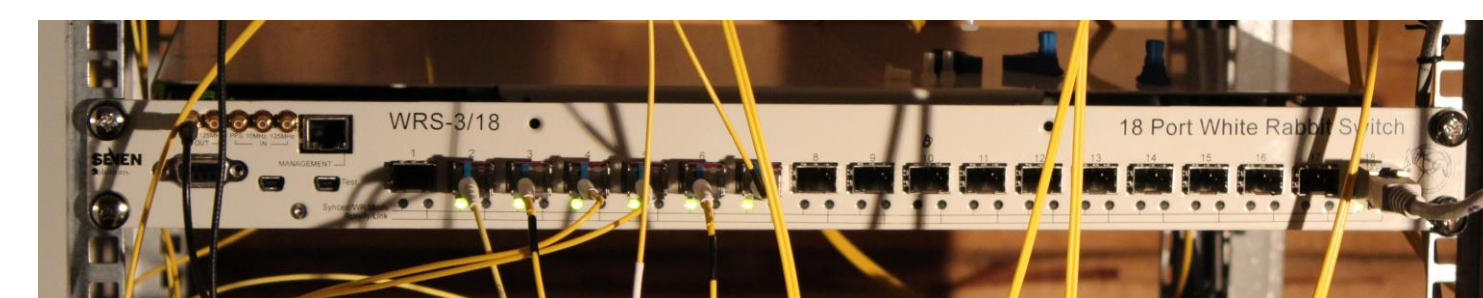

White Rabbit Switch with 18 ports with 1 Uplink Port

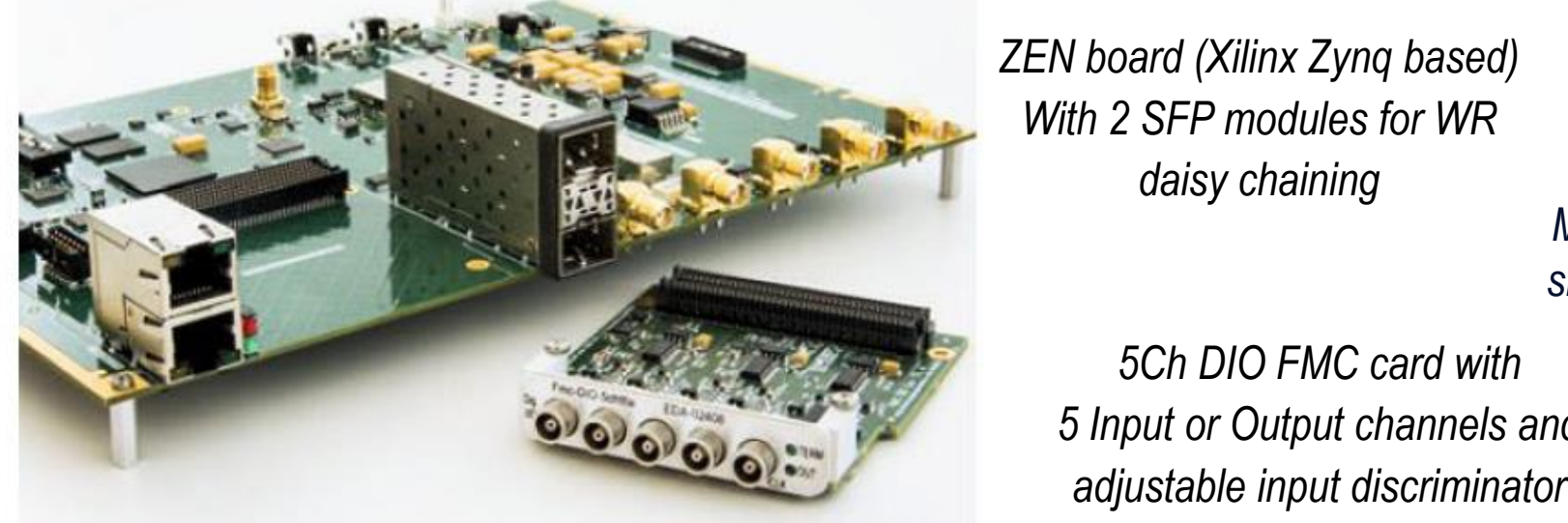

ZEN board (Xilinx Zynq based) With 2 SFP modules for WR daisy chaining



5Ch DIO FMC card with 5 Input or Output channels and adjustable input discriminator

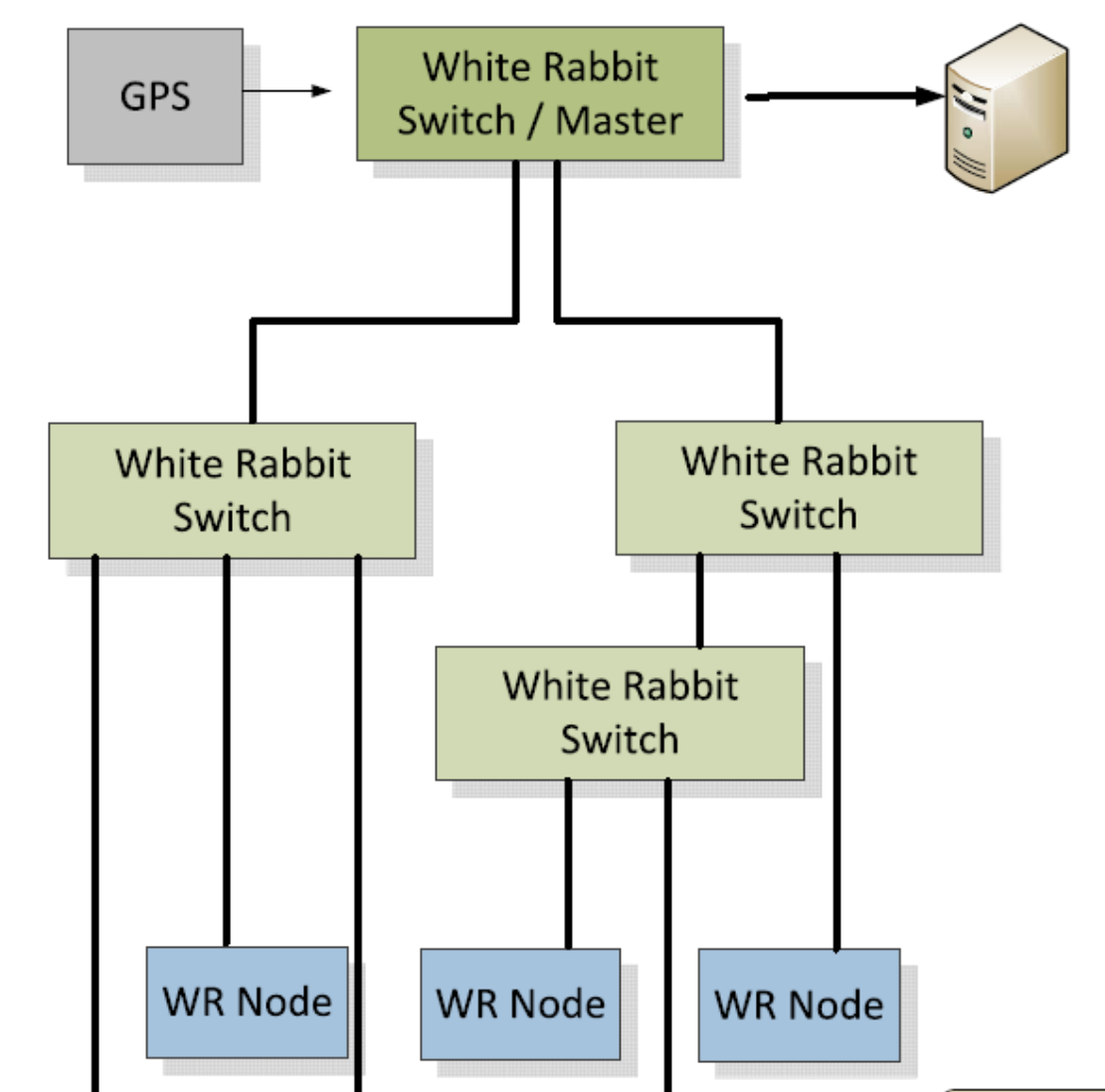

The White Rabbit network: made up of WR-switches (WRS), Grand Master and normal WRS, and of WR-nodes. The WR-nodes deliver clock-signals to, and/or extract time-stamp signals from the associated detectors (or telescopes), as symbolized for the lower-right WR-node.

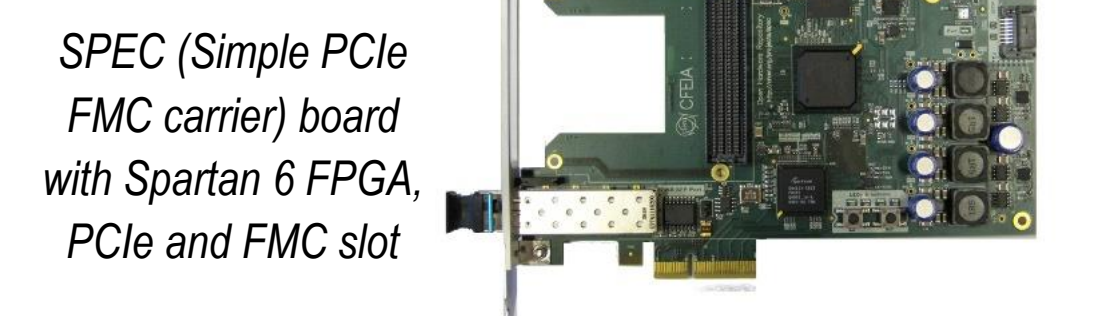

SPEC (Simple PCIe FMC carrier) board with Spartan 6 FPGA, PCIe and FMC slot

HiSCORE experiment [5]

- Cosmic- and gamma rays emit Cherenkov light and radio pulses in the atmosphere
- Multiple detectors distributed over a large area 1km²-100km²
- 28 station prototype (0.25km²) installed in Tunka, Siberia
- Each station detects Cherenkov light with 4 PMTs
- For an angular resolution of 0.1 degree timestamps with 1ns resolution is needed

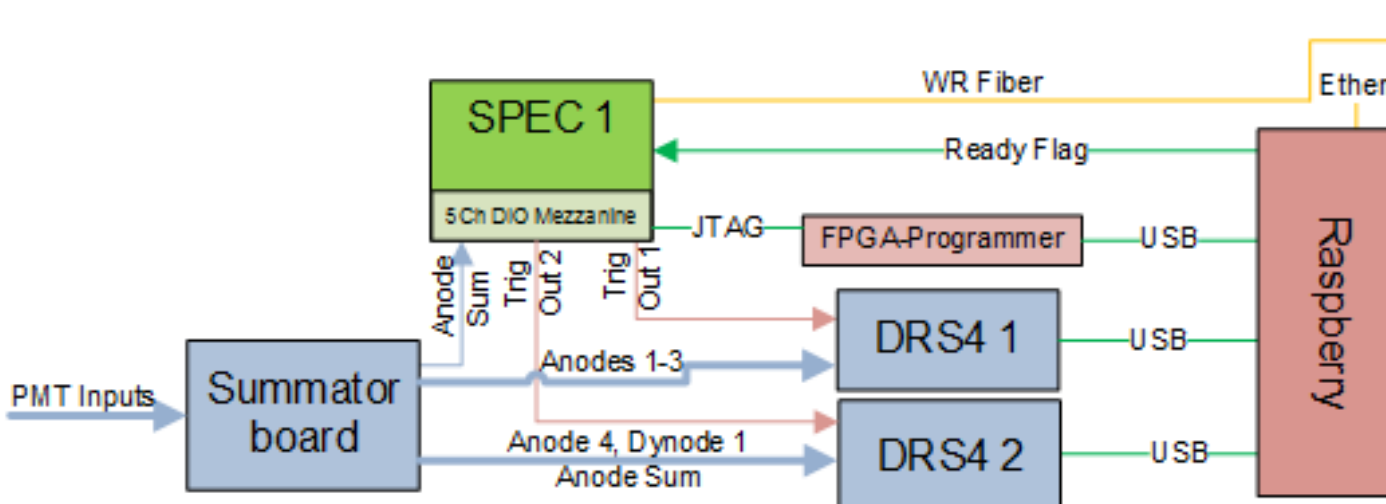
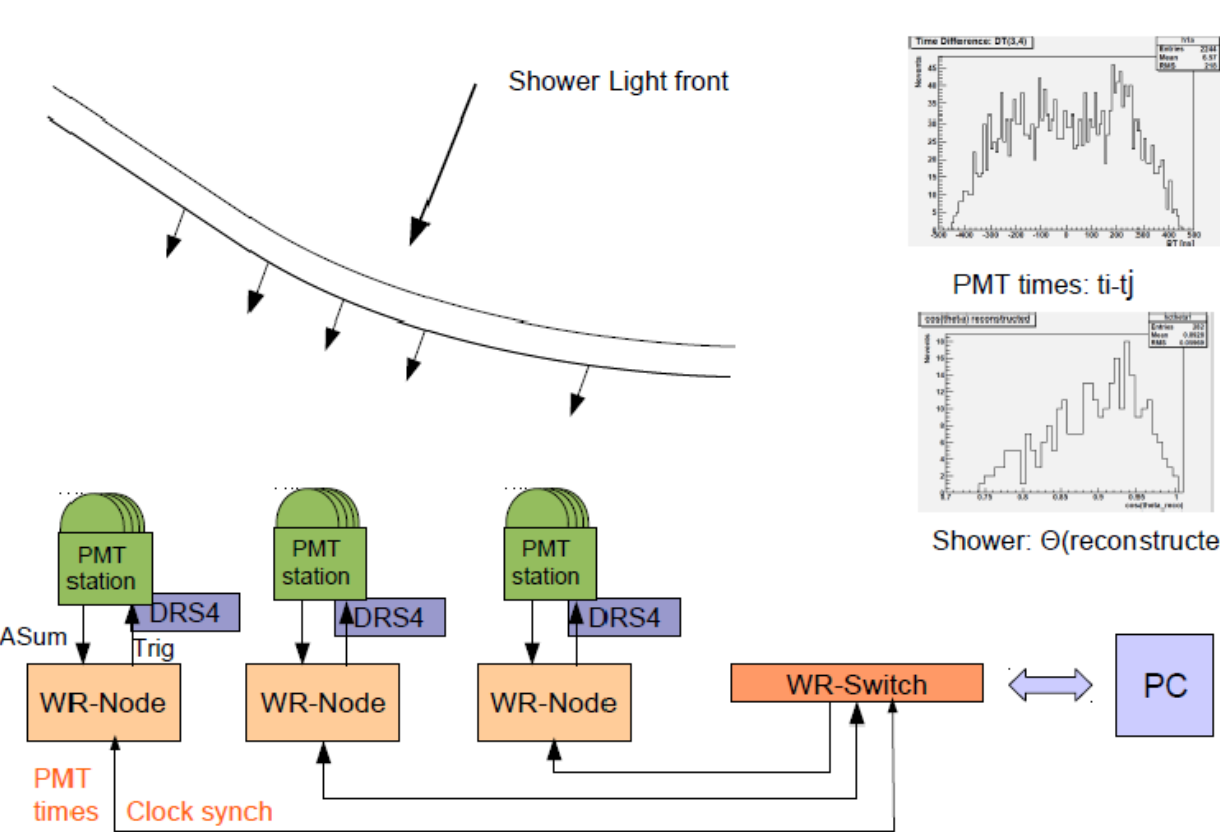
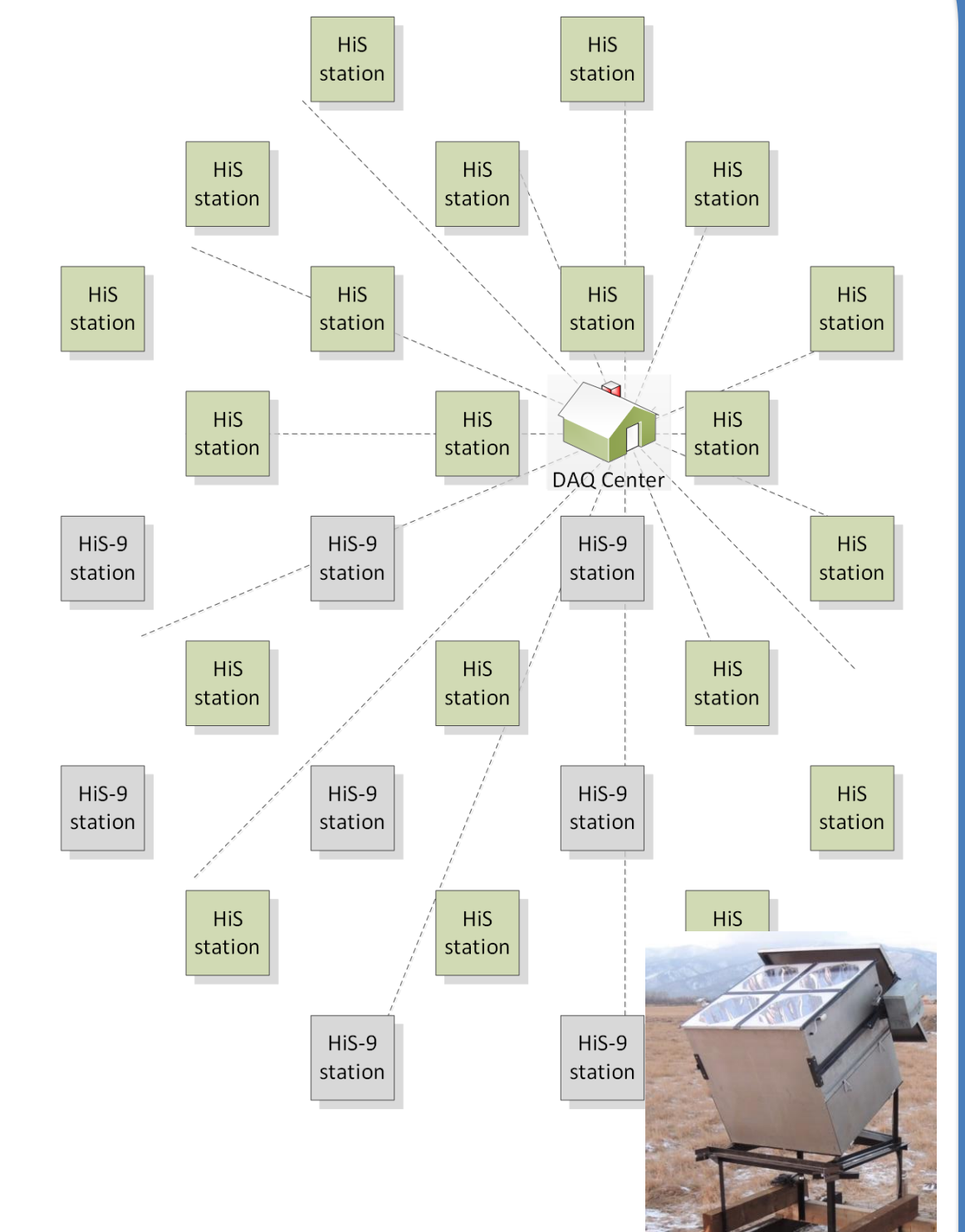

Station WR readout electronic with a SPEC board [2][3]. Analog input triggers spec and readout is started by the Raspberry. Handshake between Raspberry and a SPEC preventing new trigger during readout. Used for the HiSCORE-9 setup.

Station readout electronic

- PMT inputs recorded on a DRS4 5GHz sampling eval board [6] triggered by the SPEC board
- Raspberry reads out the DRS4 boards
- Ready Flag as Handshake between SPEC and Raspberry
- WR Fiber for timestamps
- Raspberry Ethernet for DRS4 data

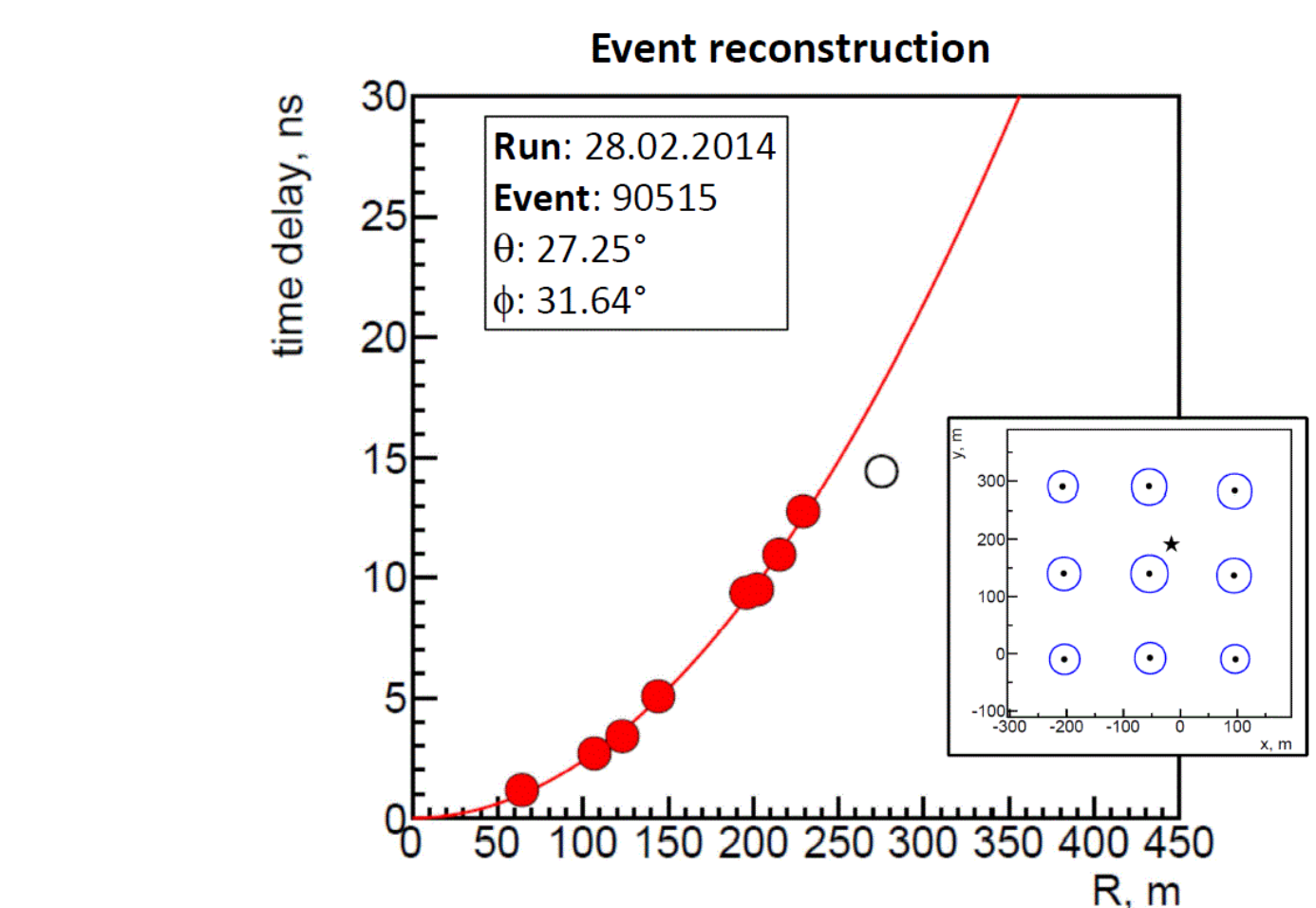

EAS shower reconstruction [4] with WR. Left: Arrival time delay vs distance R from the shower axis; for an event. Red/white dots: stations retained/excluded in the final fit; red line: reconstructed shower profile. Small panel: Reconstructed core position (black star), the area of the circles is proportional to log(A), with A the station signal amplitude.

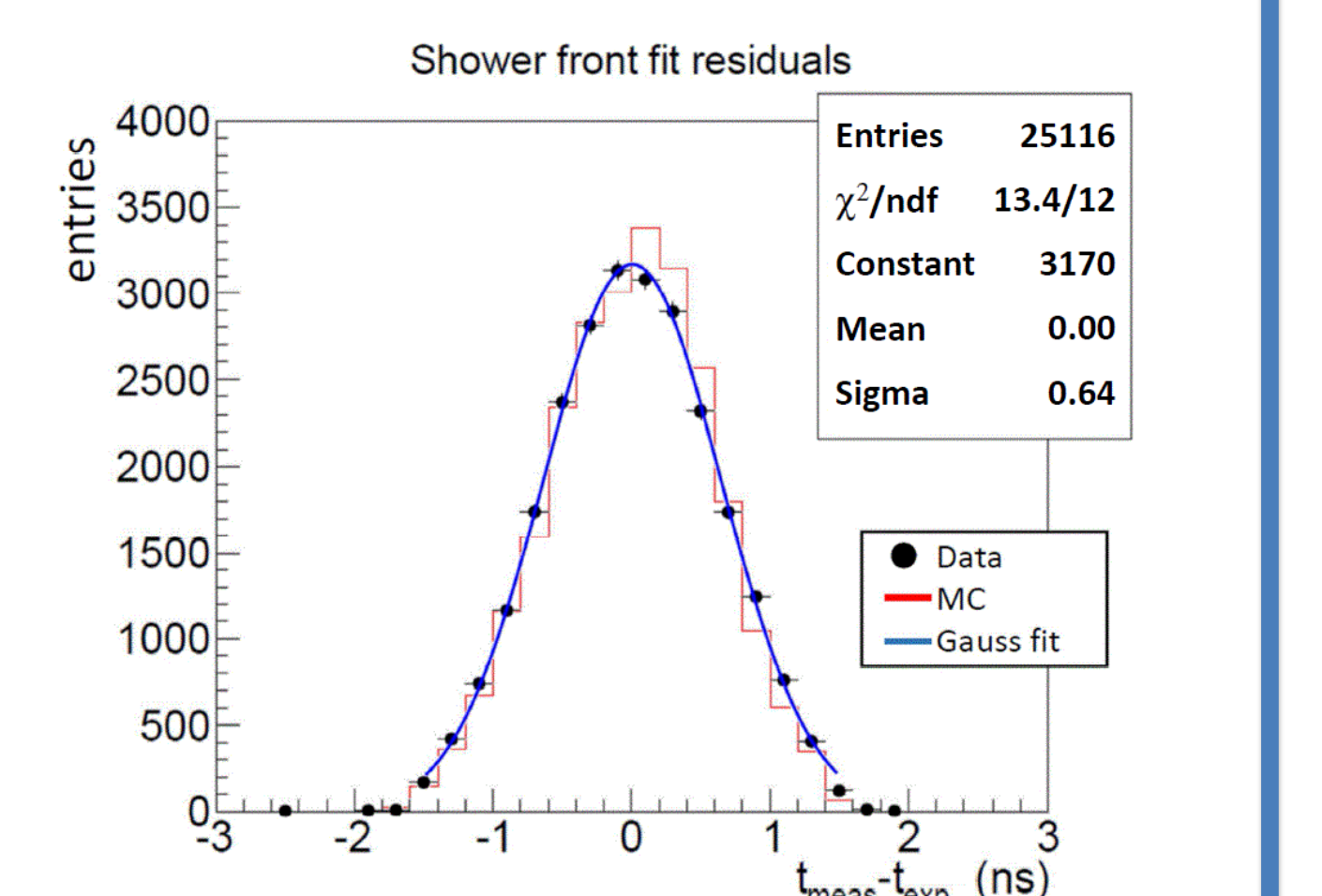

Right: Distribution of fit residuals after shower reconstruction. Black dots: data; Red line: simulated events; Blue line: Gaussian data fit.

Conclusions

- Large scale astroparticle experiments need nsec-timing
- WR perfectly fits these requirements (Clock distribution, Trigger time stamping, ...)
- WR has been implemented and operating in HiSCORE
- Zynq board has more possibilities as a standalone device (Analyzing time stamps on the fly in firmware and software, receiving neighboring time stamps)

References

[1] J. Serrano, P. Alvarez, M. Cattin, E. G. Cota, P. M. J. H. Lewis, T. Wlostowski et al., The White Rabbit Project in Proceedings of ICALEPCS TUC004, Kobe, Japan, 2009.
 [2] M. Brückner et al., "Time Synchronization with White Rabbit - Experience from Tunka-HiSCORE", ICRC2015, Proceedings of the 34th ICRC 2015, The Hague, Netherlands, Proceedings of Science PoS (ICRC2015) 1041
 [3] M.Brückner and R.Wischnewski, "A White Rabbit setup for sub-nsec synchronization, timestamping and time calibration in large scale astroparticle physics experiments", Proceedings of the 33rd ICRC 2013, Rio de Janeiro, Brazil, Braz.J.Phys. 44 (2014) no.5, p 1146
 [4] A. Porelli et al., "Timing calibration and directional reconstruction for Tunka-HiSCORE", ECRS2014, Proceedings of the 24th ECRS 2014, J. Phys. Conf. Ser. 632 (2015) 012041
 [5] M.Tluczykont et al., DOI: 10.1016/j.astropartphys.2014.03.004
 [6] DRS4 evaluation board: Stefan Ritt, Paul Scherer Institut, <http://www.psi.ch/drs/evaluation-board>