



# Introduction to *Accelerator Physics*.

DESY Summer Student Lecture 2009

Winni Decking

DESY –MPY–

# Accelerator: A Definition

---

Device that provides accelerated particles with defined and controllable properties:

- Particle Species (electron, proton, ion)
- Energy
- Direction
- Time structure
- Intensity
- Density

Accelerators are tailored to applications needs

Employ cutting edge and special developed technology to advance parameter space in any of the above areas

- **Direct particle beams on specific targets or collide beams with each other**
- **Produce thin beams for synchrotron light**
- HEP: structure of atom, standard model, ...
- Bombard targets to obtain new materials with different properties
- Synchrotron radiation: spectroscopy, X-ray diffraction, X-ray microscopy, crystallography (of proteins), ...
- Medicine: use for Positron Emission Tomography (PET), cancer therapy, surgery
- Nuclear waste transmutation (conversion of long lived into short lived nuclides)

# Accelerators Worldwide



CATEGORY	NUMBER
Ion implanters	7000
Industry	1500
Radiotherapy	7500
Medical isotopes	200
Hadron therapy	20
non-nuclear research	1000
SR sources	70
Nuclear & Particle physics res.	120
<b>TOTAL</b>	<b>17390</b>

courtesy W. Mondelaers, JUAS 2004



- Basic knowledge
  - relativistic particle dynamics
  - classical theory of electromagnetism (Maxwell's equations)
  
- Advanced Studies
  - Hamiltonian mechanics, optical concepts
  - Quantum scattering, radiation of charged particles
  - Statistical mechanics
  - Surface physics
  - Computing, ....

# What we will do

---

- Historical introduction
- Review of relativity
- Acceleration concepts
- Ring concepts
- Optical Functions
- Luminosity
- Synchrotron Radiation
  
- Questions and discussions

# Rutherford Scattering

1906 – 1913 using  $\alpha$  particles from a radioactive source to bombard a thin gold foil:

Discovery of massive, non point-like structure of the nucleus

1927 E. Rutherford says, addressing the Royal Society : “... if it were possible in the laboratory to have a supply of electrons and atoms of matter in general, of which the individual energy of motion is greater even than that of the alfa particle, .... this would open up an extraordinary new field of investigation....”

But bright sources with such energies were not yet available: man-made devices, mainly built to produce X-rays, operated at the time in the hundred KV range.

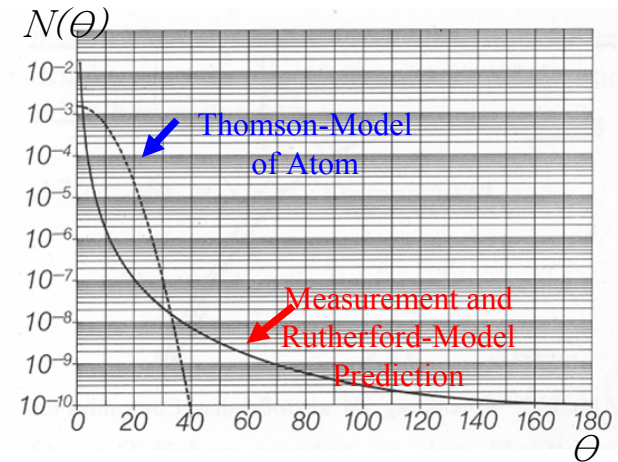

Villard X-ray Tube 1898-1905

Relativistic Energy

$$E = mc^2 = m_0 \gamma c^2$$

Relativistic Momentum

$$p = mv = m_0 \gamma \beta c$$

$$\beta = \frac{v}{c} \quad \gamma = \frac{1}{\sqrt{1 - \frac{v^2}{c^2}}} = \frac{1}{\sqrt{1 - \beta^2}}$$

Relationship between Momentum and Energy

$$E^2 = p^2 c^2 + m_0^2 c^4$$

Kinetic Energy

$$T = E - m_0 c^2 = m_0 c^2 (\gamma - 1)$$



# Basic Principles: Relativity



Speed of Light

$$c = 2.9979 \times 10^8 \text{ m/s}$$

Electron Rest Mass

$$m_{0,electron} = 511 \text{ keV}/c^2$$

Proton Rest Mass

$$m_{0,proton} = 938.3 \text{ MeV}/c^2$$

Electron Charge

$$e = 1.6021 \times 10^{-19} \text{ Coulomb}$$

Electron Volts

$$1 \text{ eV} = 1.6021 \times 10^{-19} \text{ Joule}$$

Energy in eV

$$E[\text{eV}] = \frac{mc^2}{e} = \frac{m_0c^2}{e} \gamma$$

Energy and rest mass

$$1 \text{ eV}/c^2 = 1.78 \times 10^{-36} \text{ kg}$$

Equation of motion under Lorentz Force

$$\vec{F} = \frac{d\vec{p}}{dt} = q(\vec{E} + \vec{v} \times \vec{B})$$

$$E^2 = \vec{p}^2 c^2 + m_0^2 c^4$$

$$\Rightarrow E \frac{dE}{dt} = c^2 \vec{p} \frac{d\vec{p}}{dt} = qc^2 \vec{p}(\vec{E} + \vec{v} \times \vec{B}) = qc^2 \vec{p}\vec{E}$$

Magnetic Fields do not change the particles energy, only electric fields do!

**Technical challenge: provide large enough electric fields**

# Electrostatic Accelerators

## Cockroft & Walton:

$$\vec{F} = q\vec{E} = q\frac{U}{d}$$

$$\Delta E = \int_a^b \vec{F} d\vec{r} = \int_a^b q\frac{U}{d} d\vec{r} = qU$$

useful unit charge × voltage = eV

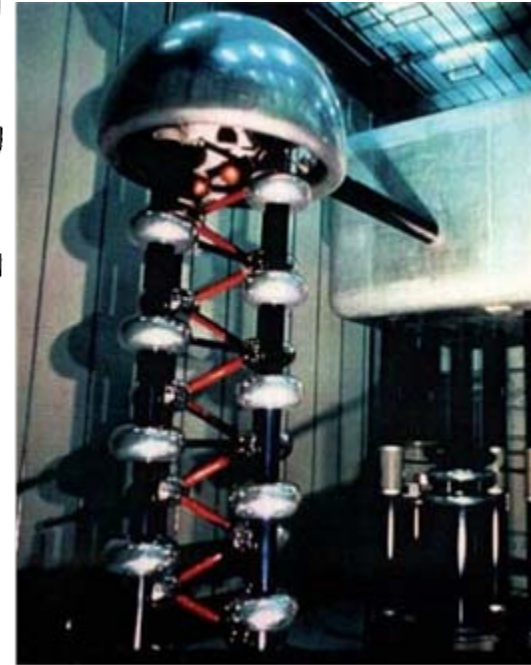
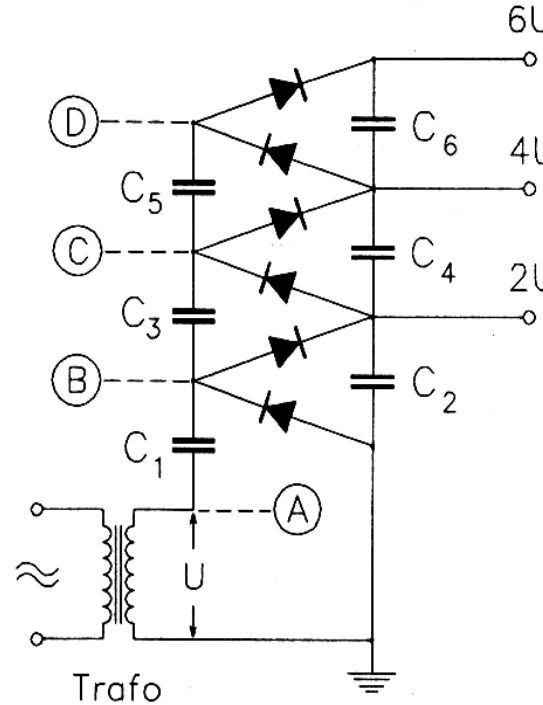

**1932:** First particle beam (protons) produced for nuclear reactions: splitting of Li-nuclei with a proton beam of 400 keV

**Today:** Proton Pre-accelerator at PSI (Villingen)

# Electrostatic Accelerators



## Van de Graaff:

- Mechanical transport of charges creates high voltages
- Maximum potential around 20 MV (needs already SF6 gas surrounding to prevent discharges)

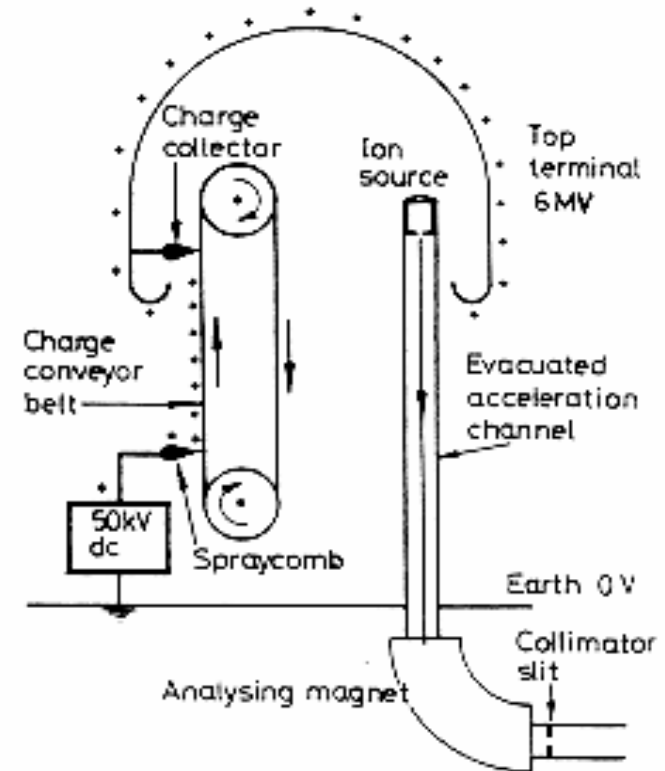

**Today:** 12 MV-Tandem van de Graaff Accelerator at MPI Heidelberg

# Linear Accelerators (Basic Principle)

Wideroe (1928): apply acceleration voltage several times to particle beam

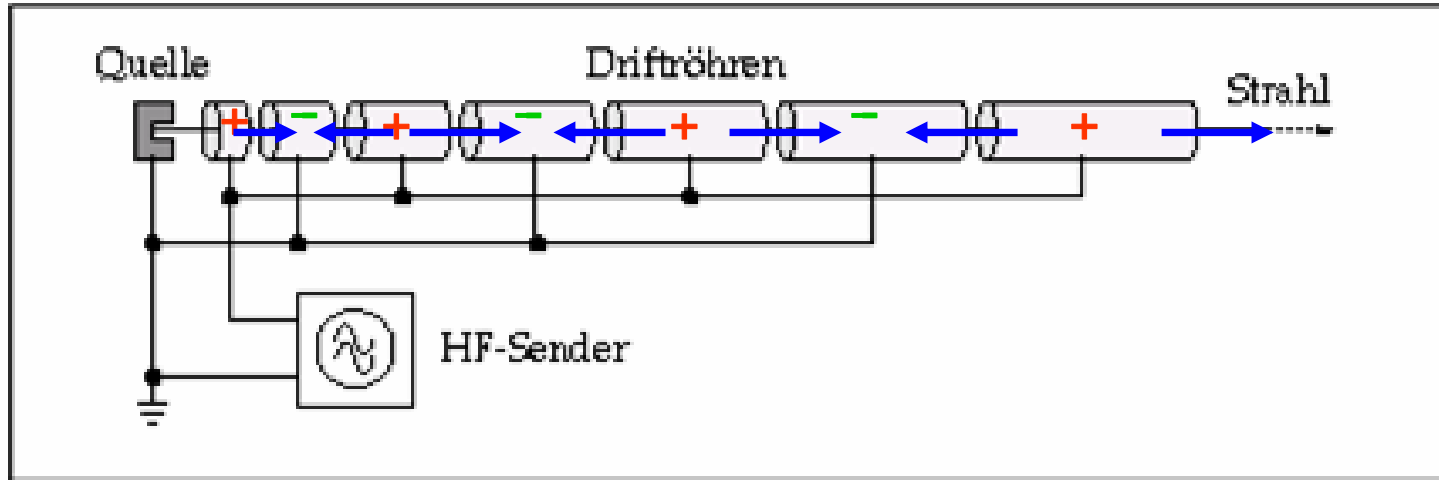

- acceleration of the particle in the gap between the tubes
- voltage has to be „flipped“ to get the right sign in the next gap
  - RF voltage
  - shield the particle in drift tubes during the negative half wave of the RF voltage
  - vary the tube length with increasing energy/velocity

# Acceleration in the Wideroe Structure

## Energy gained after $n$ acceleration gaps

$$E_n = n * q * U_0 * \sin \psi_s$$

$n$  number of gaps between the drift tubes

$q$  charge of the particle

$U_0$  Peak voltage of the RF System

$\Psi_s$  synchronous phase of the particle

## Kinetic energy of the particles

$$E_n = \frac{1}{2} m * v_n^2$$

valid for **non relativistic** particles ...

=> velocity of the particle

$$v_n = \sqrt{\frac{2E_n}{m}} = \sqrt{\frac{2 * n * q * U_0 * \sin \psi_s}{m}}$$

shielding of the particles during the negative half wave of the RF

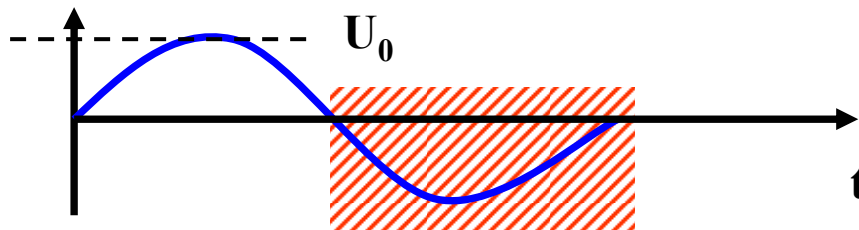

Length of the  $n$ -th drift tube:

$$l_n = v_n * \frac{\tau_{RF}}{2} = v_n * \frac{1}{2\nu_{RF}}$$

## DESY proton linac (LINAC III)

$$E_{total} = 988 \text{ MeV}$$

$$E_{kin} = E_{total} - m_0 c^2$$

$$E_{kin} = 50 \text{ MeV}$$

$$E^2 = c^2 p^2 + m_0^2 c^4$$

$$p = 310 \text{ MeV} / c$$

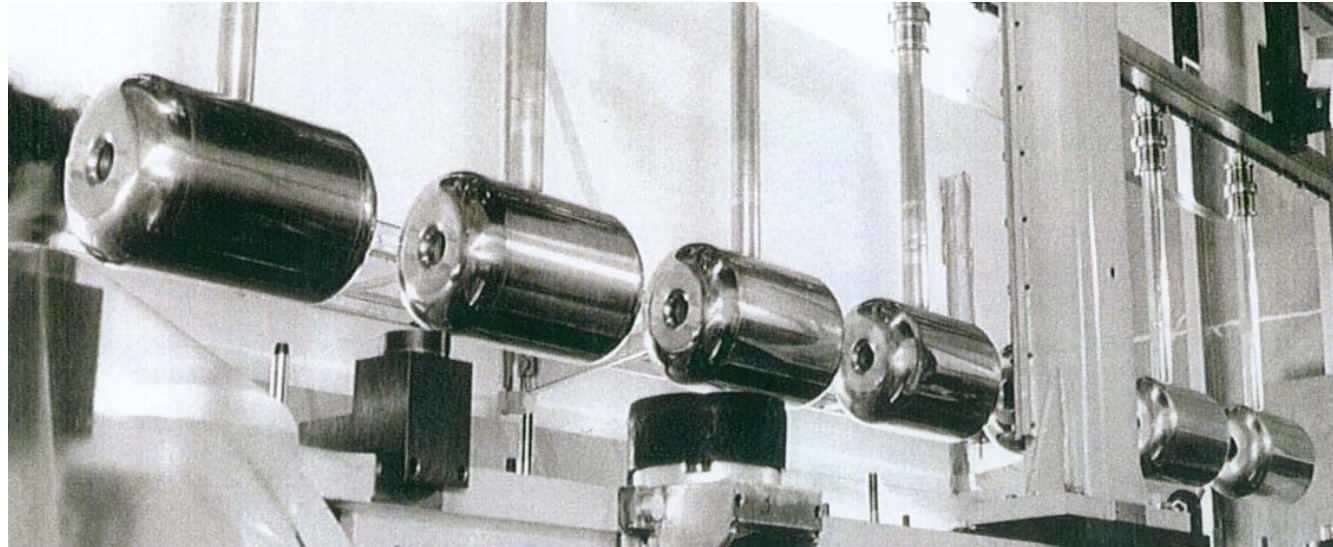

## GSI Unilac

$E \approx 20 \text{ MeV per Nukleon}$

$\beta \approx 0.04 \dots 0.6$

Protons/Ions

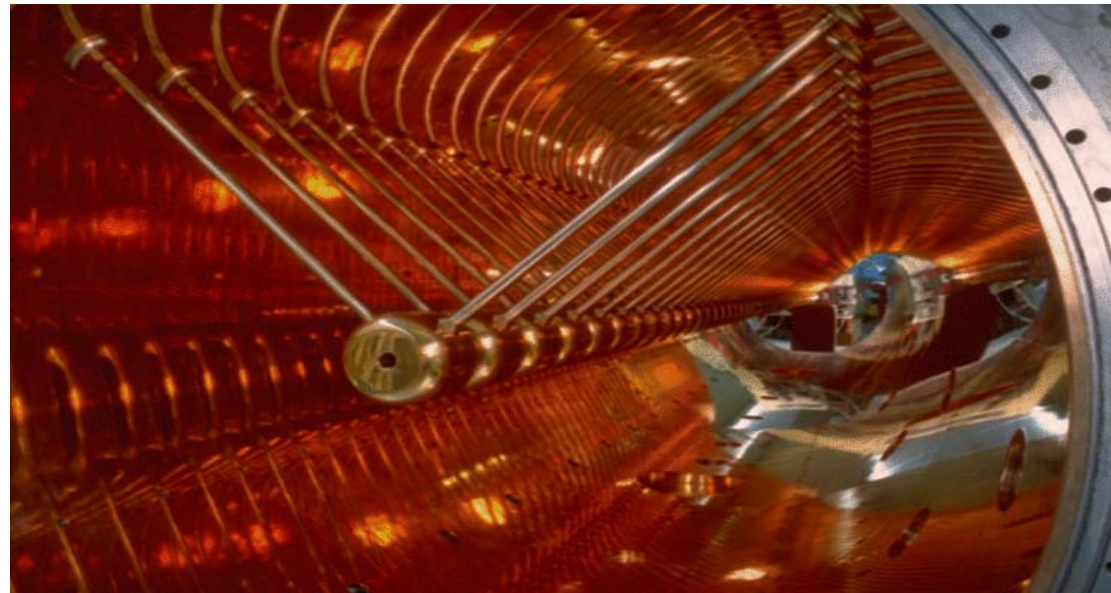

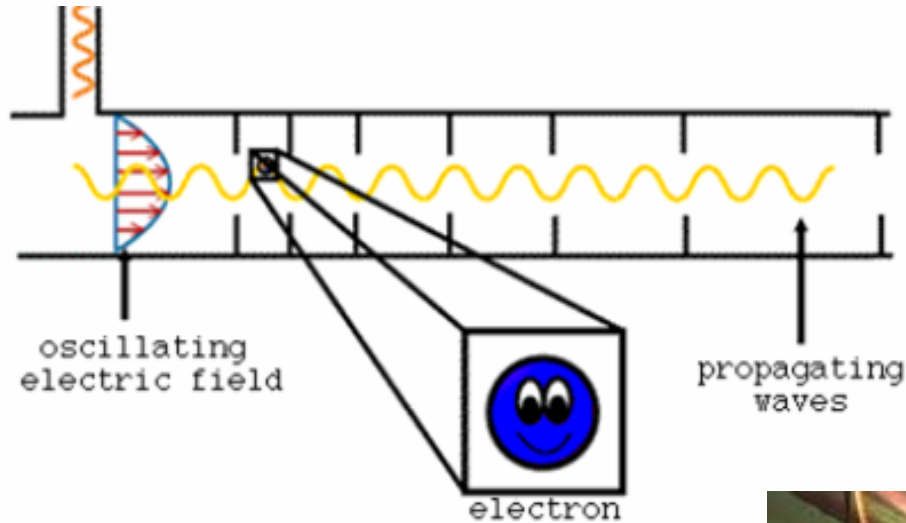

Traveling wave structure:

- Particles in phase with waveform
- Reduce phase velocity in waveguide with irises

## Example: SLAC 2 mile LINAC

E up to 50 GeV  
in operation since mid 60's  
Electrons/Positrons  
 $\nu = 2.8 \text{ GHz}$ , 35 MV/m





# Klystron

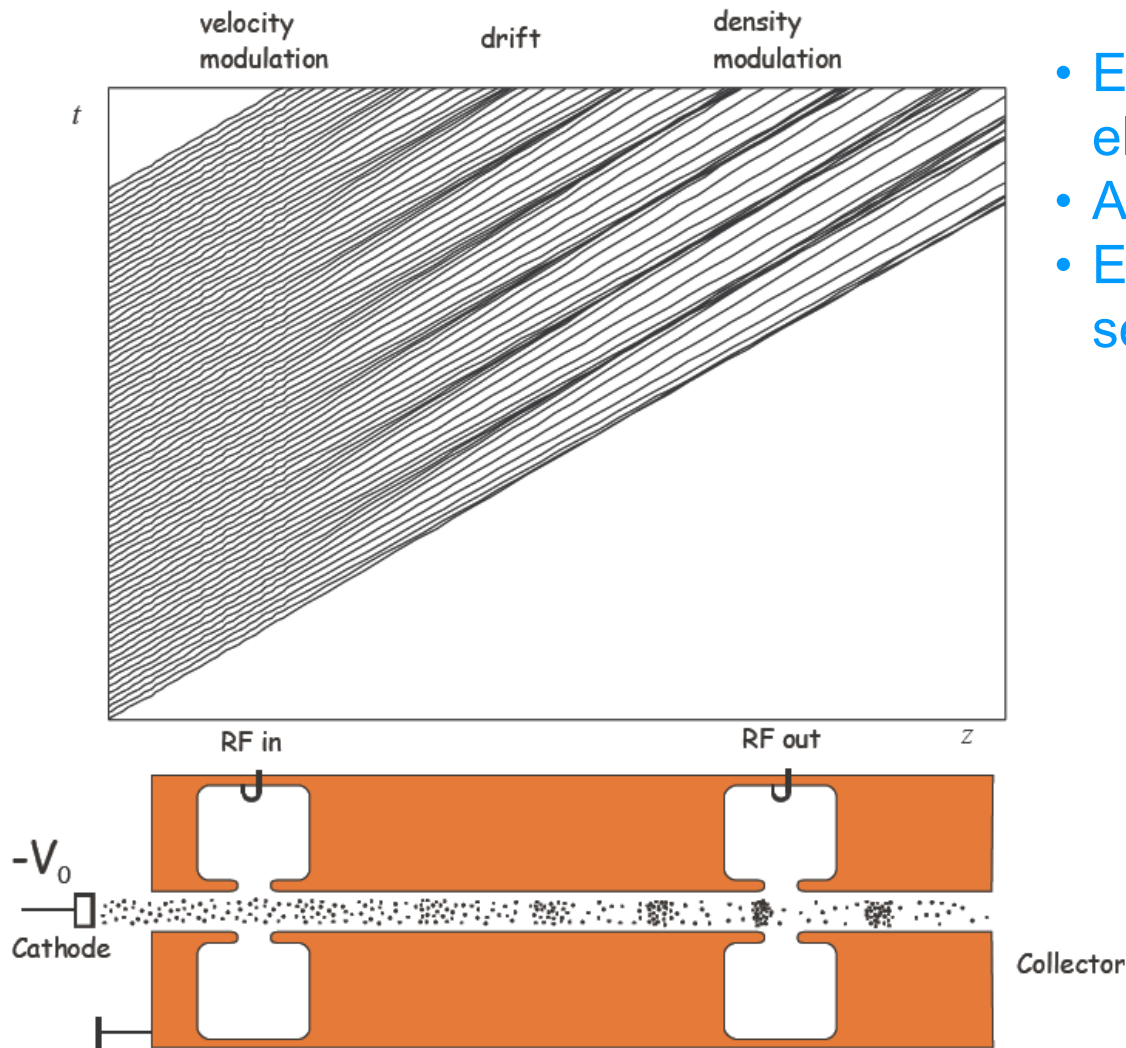

- Energy/velocity modulated electron beam in first resonator
- After drift density modulation
- Electric field extracted in second resonator



courtesy E. Jensen, RF for LINACS, CAS 2005

# What is relativistic?

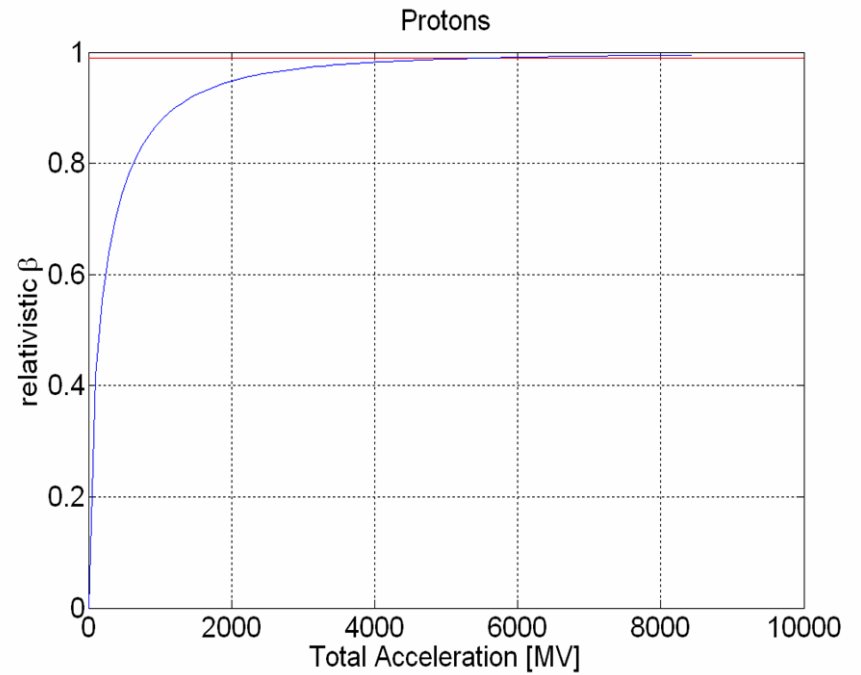
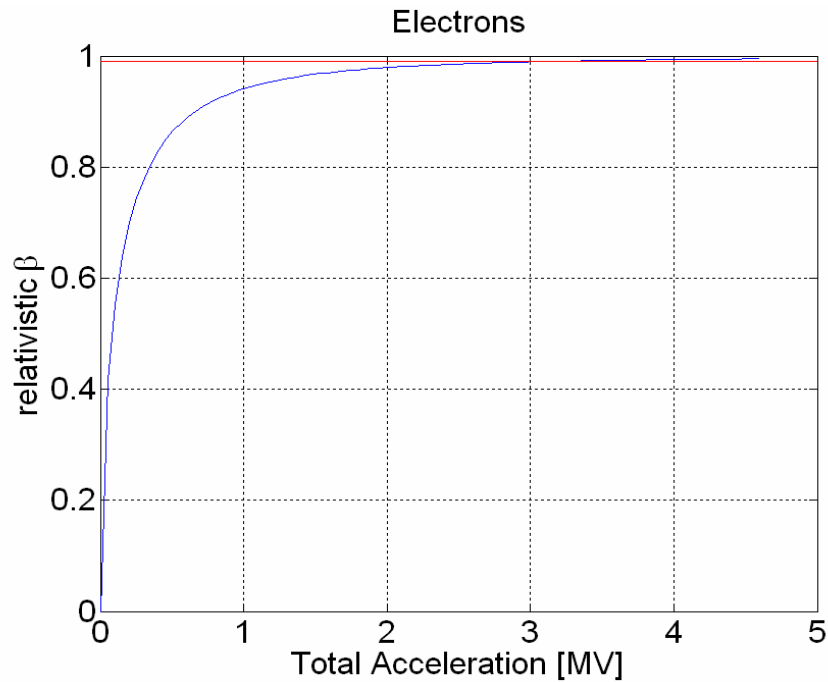

**Electrons:  $\beta > 0.99$  at 3.7 MeV**

**Protons:  $\beta > 0.99$  at 6.7 GeV**

# Motion in a constant B-field (E=0)

- Energy stays constant
- Spiraling trajectory along the uniform magnetic field

Lorentz Force

$$\vec{F} = q * (\vec{v} \times \vec{B})$$

Zentrifugal Force

$$F = \frac{m * v^2}{\rho}$$

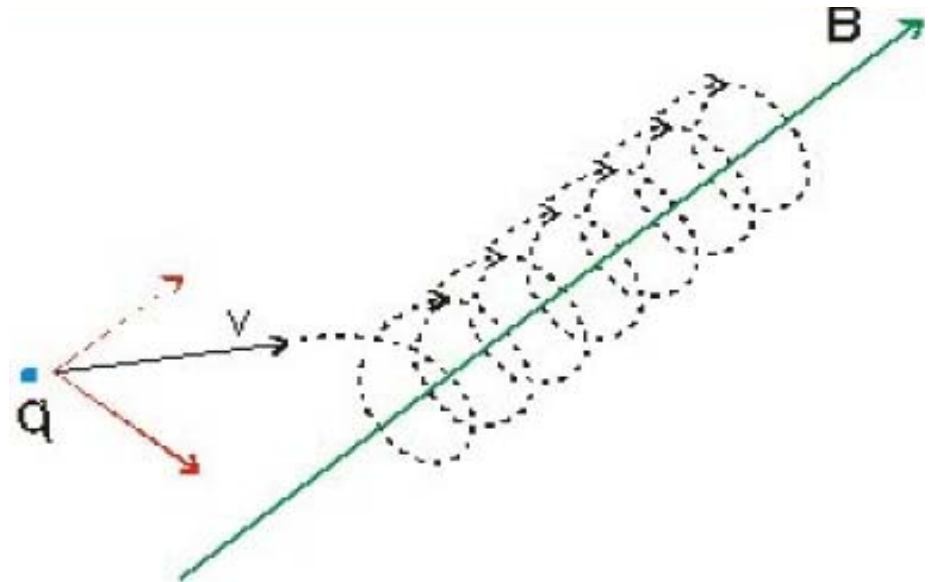

$$q * v * B = \frac{m * v^2}{\rho} \quad \rightarrow \quad B * \rho = p / q$$

# Cyclotron

Uses magnetic field to force particles to pass through accelerating fields at regular intervals

Cyclotron:

- **Constant B-field**
- Time for one revolution

$$T = 2\pi \frac{\rho}{v} = 2\pi \frac{m}{q * B_z}$$

- Constant revolution frequency = constant accelerating frequency

$$\omega_z = 2\pi \frac{1}{T} = \frac{q}{m} * B_z \rightarrow \omega_z = const.$$

- Works only if  $m=const \Rightarrow$  non-relativistic particles
- Large momentum  $\Rightarrow$  large magnets

$$B * \rho = \frac{p}{q}$$

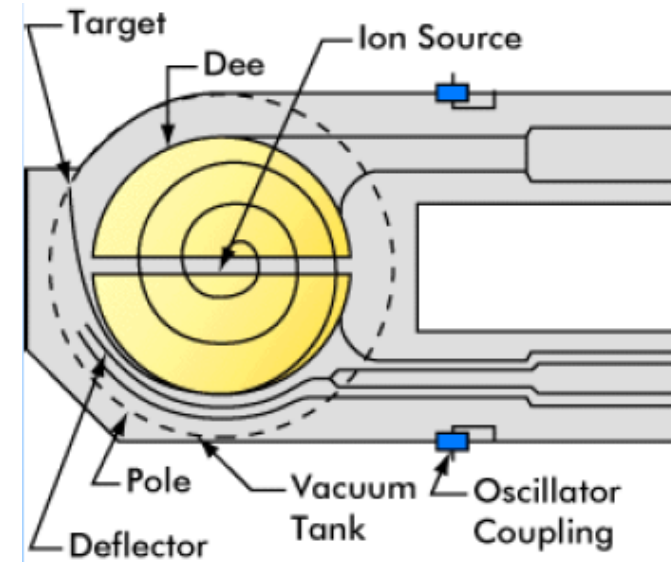

E. Lawrence and his first cyclotron

# Synchrotron

- Varying B-field
- Constant  $\rho$

$$B * \rho = \frac{p}{q}$$

- Increase B-field synchronous to momentum p

Where is the acceleration?

- RF field in accelerating cavity with the right (synchronous) phase

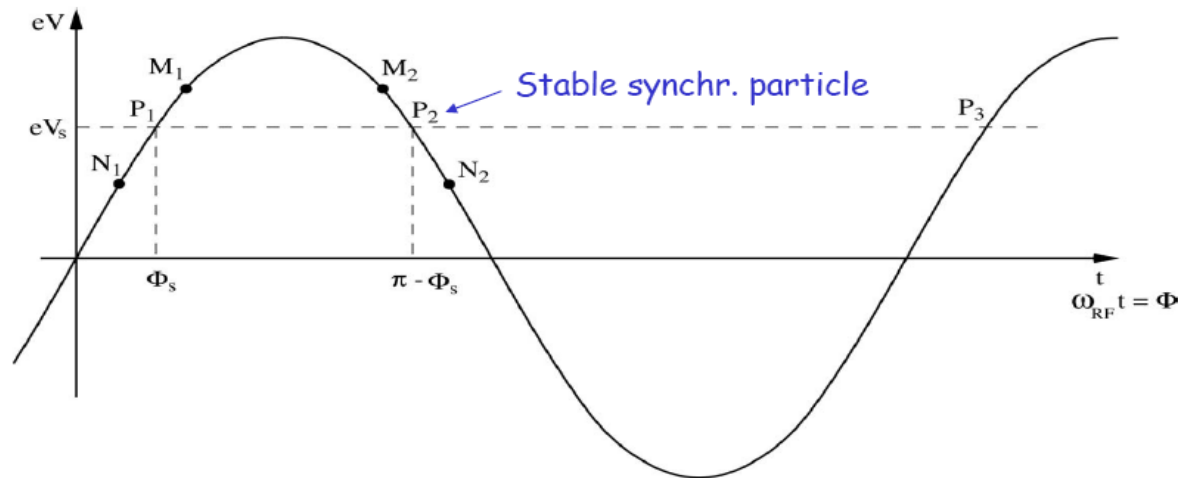

$$\frac{\Delta p}{q} = eU_0 \sin(\phi)$$

Increase  $B \rightarrow$  decreases  $\rho \rightarrow$  particle comes early  $\rightarrow$  gains more energy

# Synchrotron

Synchronous accelerator where there is a synchronous RF phase for which the energy gain fits the increase of B-field at each turn.

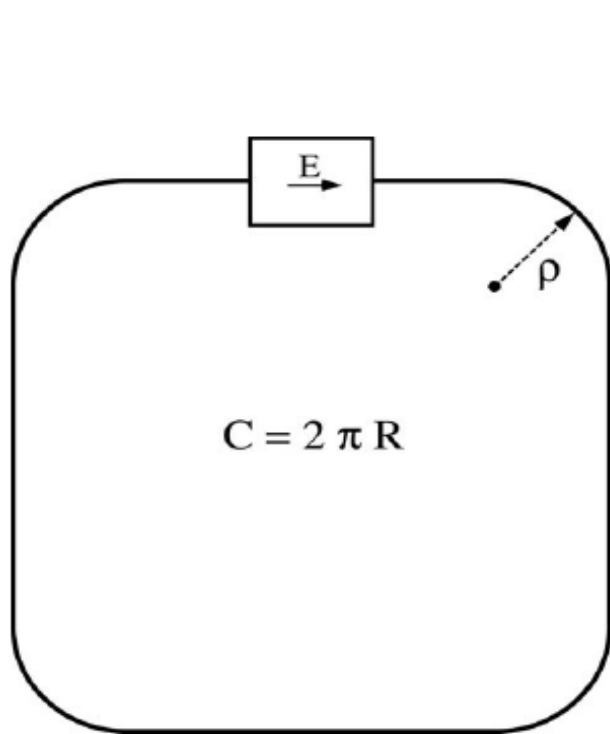

$$\tau = \frac{2\pi R}{v} \approx \frac{L}{c}$$

revolution time

$$\frac{\omega}{2\pi} = \frac{1}{\tau} \approx \frac{c}{L}$$

revolution frequency

$$\omega_{rf} = h\omega \approx \frac{hc}{L}$$

RF frequency  
 $h$  = harmonic number  
 = number of possible bunches

$$\rho = \left| \frac{p}{qB} \right|$$

Magnetic rigidity

$$B\rho = \frac{p}{q}$$

# Magnetic Dipole Fields

**Technical design of a dipole magnet:**  
 a magnet with two flat, parallel pole shoes  
 creates a homogeneous dipole field

Maxwells equations:  $\vec{\nabla} \times \vec{H} = \vec{j} + \frac{\delta \vec{D}}{\delta t}$

$$\int_A (\vec{\nabla} \times \vec{H}) \cdot \vec{n} da = \oint \vec{H} d\vec{s} = h * H_0 + l_{Fe} * H_{Fe} = nI$$

$$H_0 = \frac{B_0}{\mu_0}, H_{Fe} = \frac{B_0}{\mu_0 * \mu_{Fe}}$$

$$B_0 = \frac{\mu_0 * nI}{h}$$

the magnetic field B depends on

- \* the current
- \* the number of windings
- \* the gap height

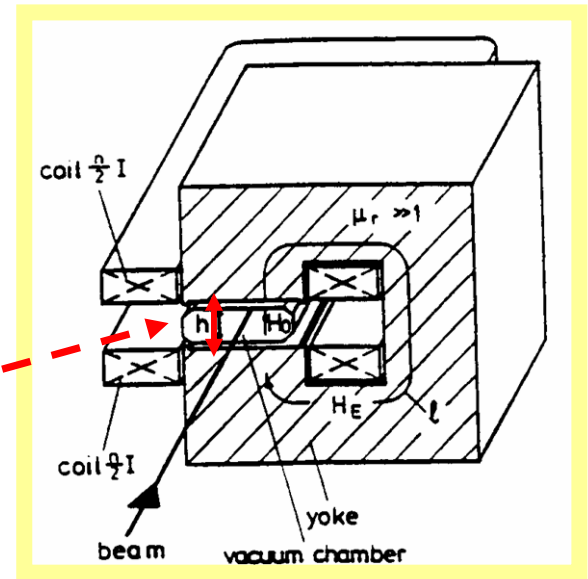

$n * I$  = number of coil windings,  
 each carrying the current  $I$   
 $\mu_r$  = rel. permeability of the material,  
 $\mu_r(Fe) \approx 3000$

# Dipole Fields and Max. Energies

For high energy machines ( $\gamma \gg 1$ )

$$E^2 = p^2 c^2 + m_0^2 c^4 \Rightarrow E \approx pc$$

$$B * \rho = \frac{p}{q} \Rightarrow B * \rho = \frac{E}{ce} \Rightarrow E \approx 0.3 \times B[\text{T}] \times \rho[\text{m}]$$

Technology

normal conducting:  $B_{\text{max}} \approx 2 \text{ T}$

super conducting :  $B_{\text{max}} \approx 7 \text{ T}$

Size (= money)



# Example: HERA p

920 GeV Proton storage ring  
dipole magnets

$N = 416$ ,  $l = 8.8\text{m}$ ,  $\rho = 580\text{ m}$ ,  $B = 5.5\text{ T}$   
total length 6.3 km (3.6 km dipoles)  
1990 till 2007

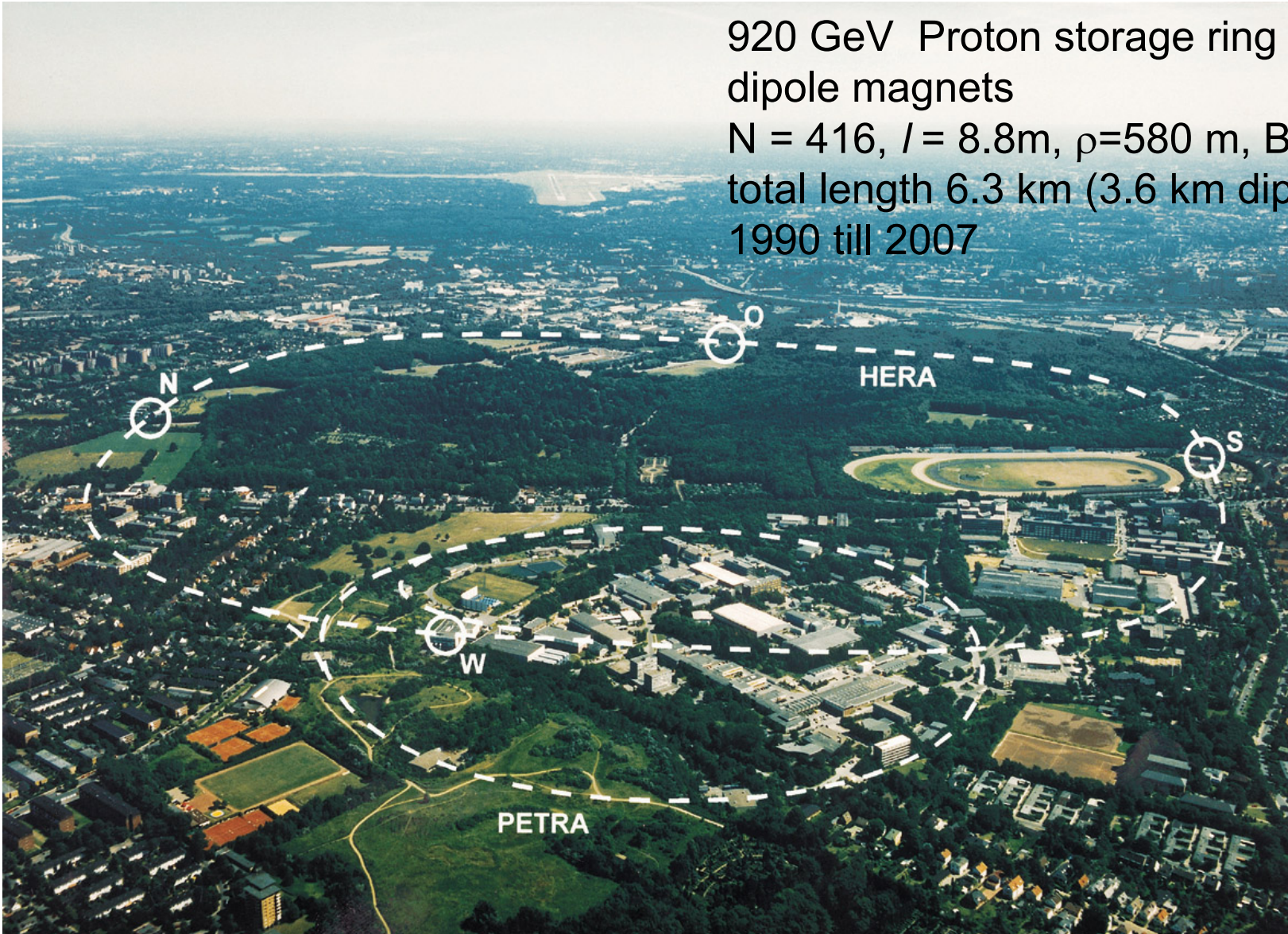

# Example LHC

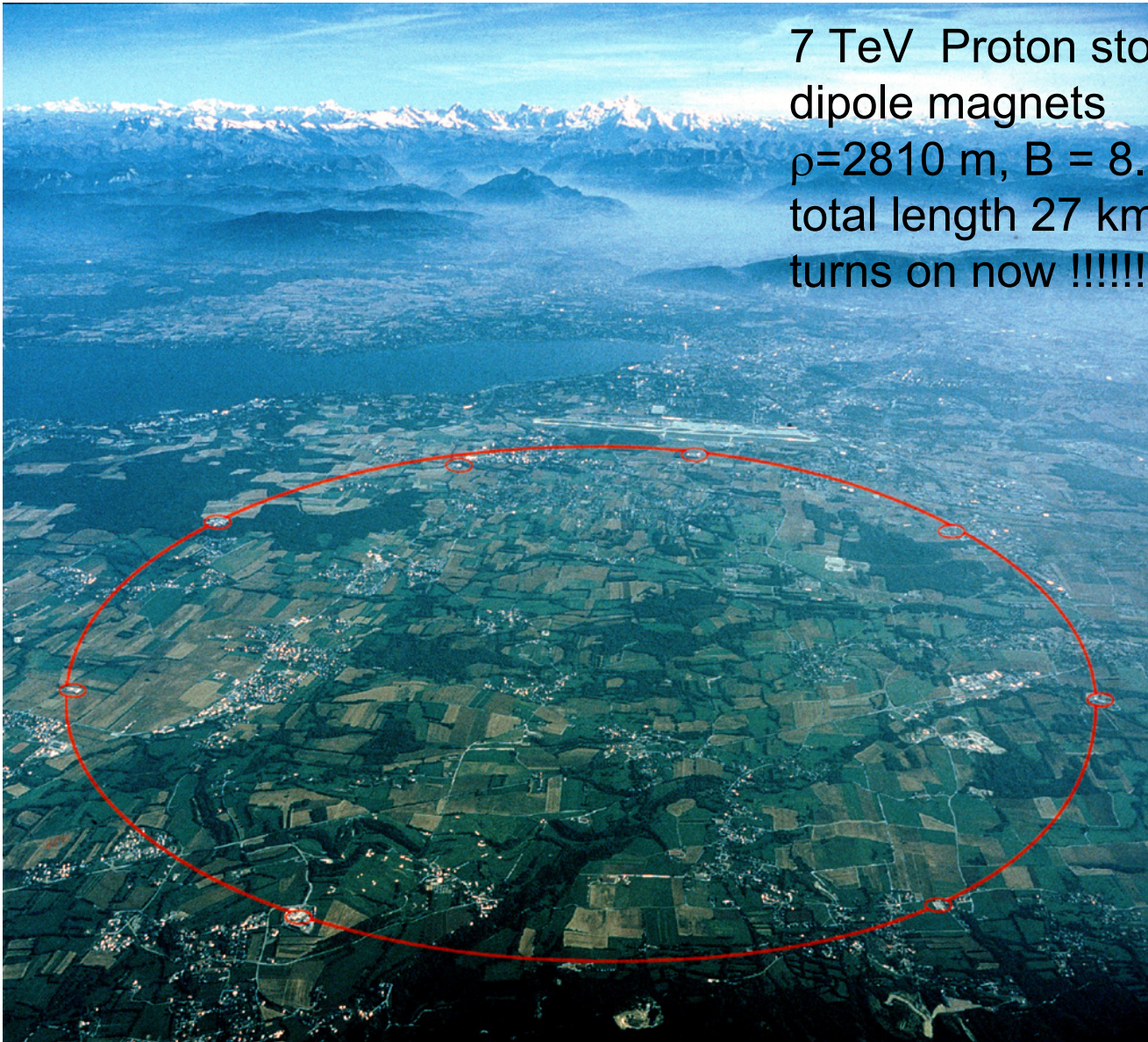

7 TeV Proton storage ring

dipole magnets

$\rho=2810$  m,  $B = 8.3$  T

total length 27 km (17.6 km dipoles)

turns on now !!!!!!!!

# HEP: The energy frontier

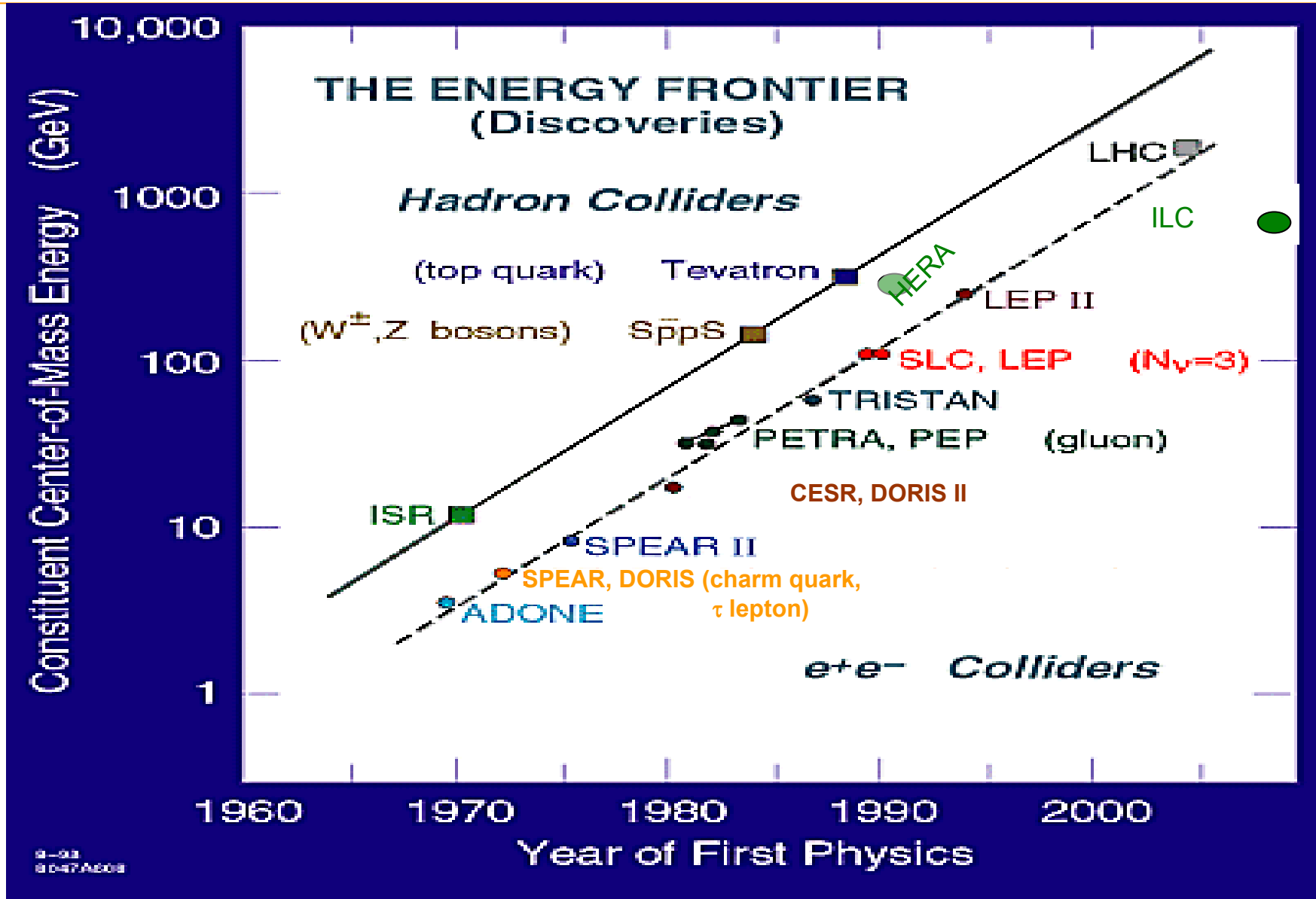

DESY  
10-47-A608

# Synchrotron Radiation

- Particles radiate when accelerated, particle moving in a dipole is accelerated centrifugally and emits radiation tangential to the trajectory

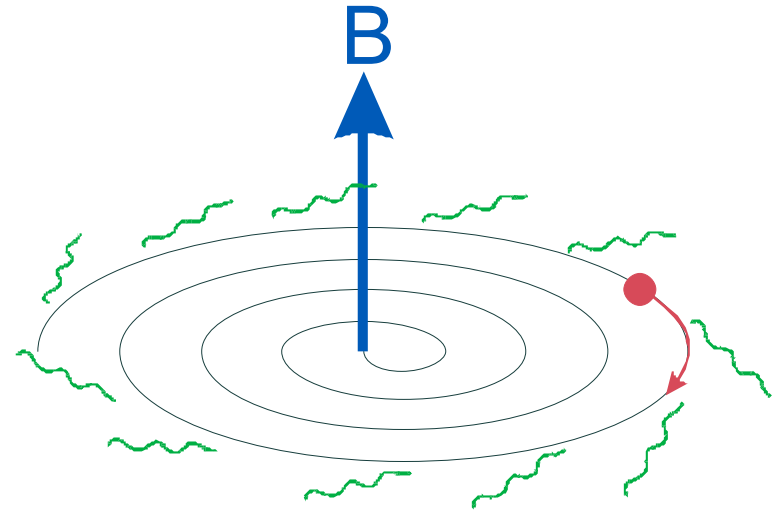

- Total energy loss after one turn:

$$\Delta E / rev [\text{GeV}] = \frac{6.034 \times 10^{-18}}{\rho [\text{m}]} \left( \frac{E [\text{GeV}]}{m_0 [\text{GeV}/c^2]} \right)^4$$

- Ratio of proton to electron mass is 1836
- At the same energy and radius:  $\Delta E_{\text{electron}} : \Delta E_{\text{proton}} \approx 10^{13}$

- Example HERA electron ring
  - $E = 27 \text{ GeV}$
  - $B = 0.16 \text{ T}$ ,  $\rho = 580 \text{ m}$
  - $\Delta E \approx 80 \text{ MeV}$
  - Lots of RF stations and power installed in HERA-e
  
- Example HERA proton ring
  - $E = 920 \text{ GeV}$
  - $B = 5.5 \text{ T}$ ,  $\rho = 580 \text{ m}$
  - $\Delta E \approx 10 \text{ eV}$
  - RF only needed for longitudinal focusing and acceleration

# Linear Collider

No Bends, but *lots* of RF!

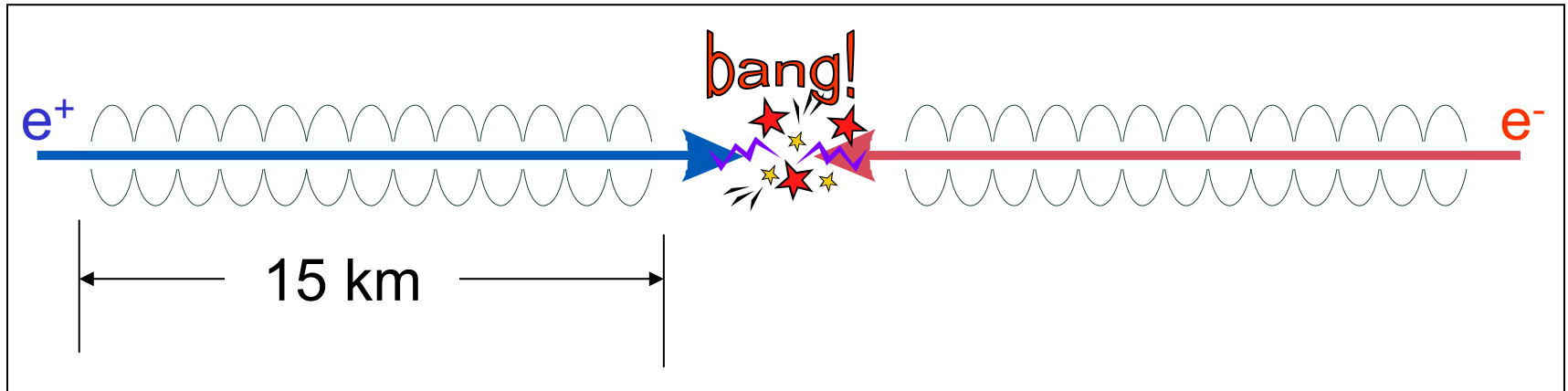

For a  $E_{\text{cm}} = 500 \text{ GeV}$ :

Effective gradient: 35 MV/m

Huge International Collaboration:  
ILC

# TESLA Superconducting RF technology

- 1.3 GHz niobium cavities
- 2 K
- 23 MV/m for XFEL
- 35 MV/m for ILC
- 10 Hz
- TTF linac

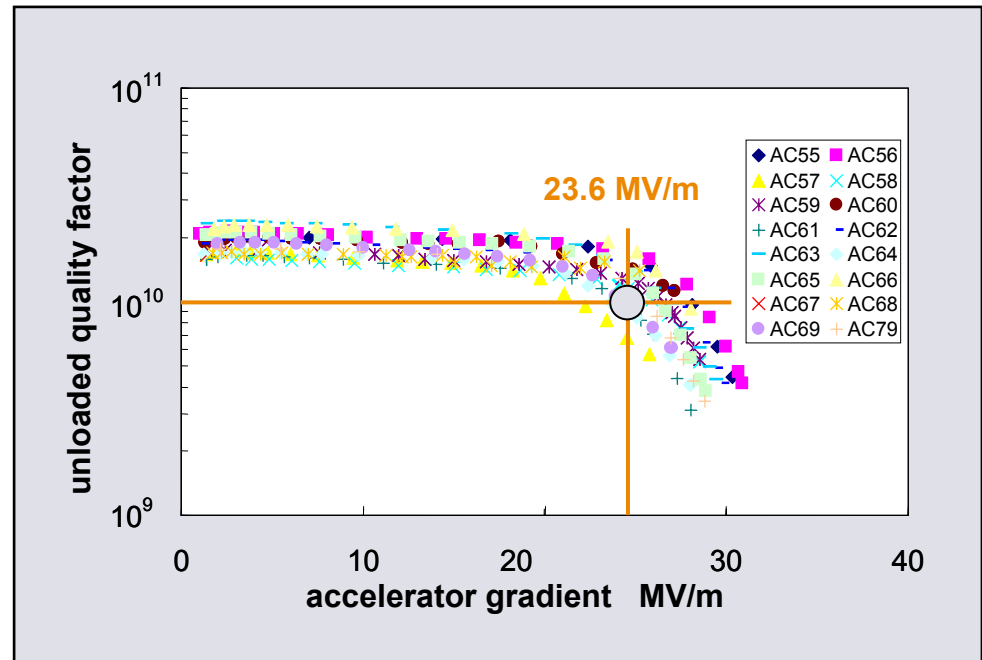

# Cavity String and Module Assembly



cold mass with cavities, magnet / BPM, HOM abs. beam pipe, valve

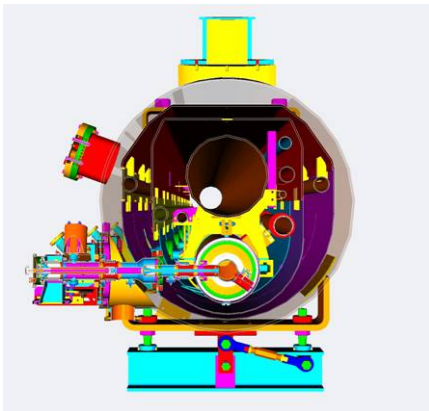
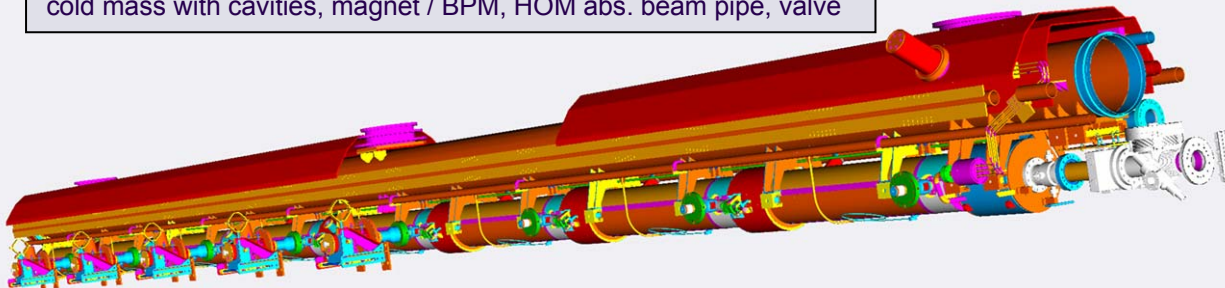

The XFEL accelerator module is based on the 3<sup>rd</sup> cryomodule generation tested at the TESLA Test Facility and designed by INFN.

Already 10 cryomodules have been built and commissioned for the TTF Linac.

Length	12.2 m
Total weight	7.8 t



# Luminosity

$$R = L * \Sigma_{react.}$$

production rate of (scattering) events is determined by the cross section  $\Sigma_{react}$  and a parameter L that is given by the design of the accelerator: ... the luminosity

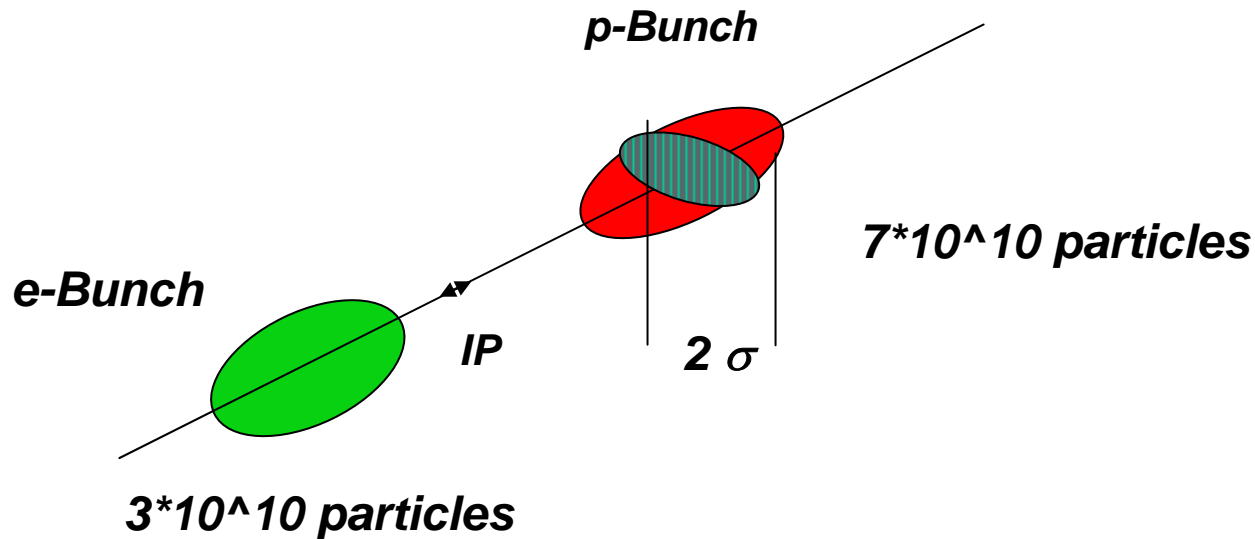

$$L = \frac{1}{4 \pi e^2 f_0 n_b} * \frac{I_e I_p}{\sigma_x^* \sigma_y^*}$$

# Synchrotron Radiation

- Radiation is produced in a narrow light cone of angle

$$\theta \approx \frac{1}{\gamma} = \frac{511}{E[\text{keV}]} \text{ for electrons and } v \approx c$$

- Radiation spot size depends thus on electron energy and beam size at source point
- A quality measure for synchrotron radiation is the brilliance (or brightness in US literature):

Photon flux (per 0.1 % bandwidth) normalized with the total horizontal and vertical photon source size and divergence

$$B = \frac{F}{4\pi^2 \sigma_x \sigma_{x'} \sigma_y \sigma_{y'}}$$

# Brightness Comparison

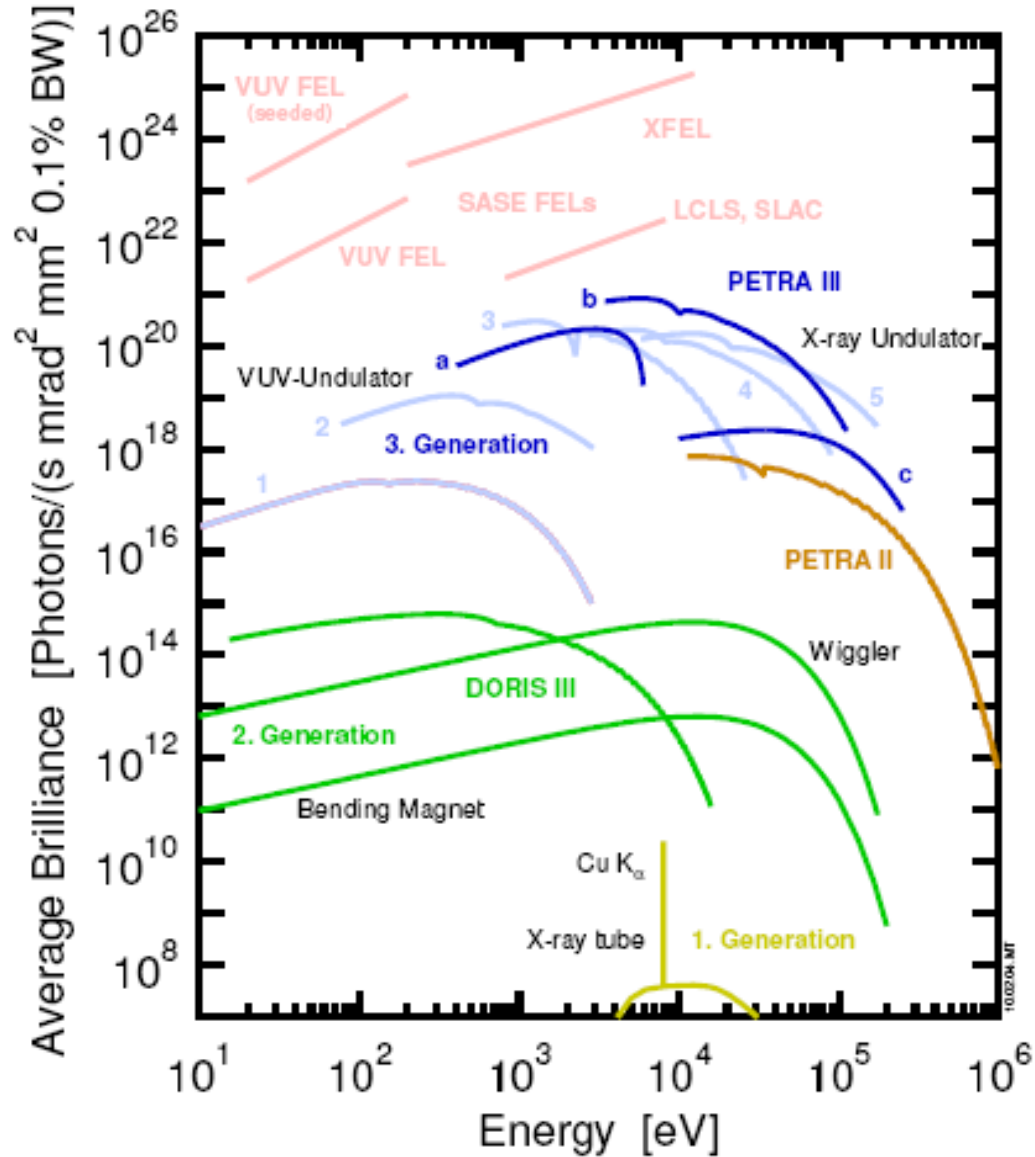

# Transverse Beam Dynamics

---

To describe the motion of particles, each particle is characterized within a six-dimensional phase space  $(x, x', y, y', s, p)$

- $x$  its horizontal (vertical) position
- $x'$  its horizontal (vertical) slope
- $s$  its longitudinal position along the accelerator
- $p$  its momentum

All particles having the design momentum  $p$  will fly happily along the accelerator with  $(0, 0, 0, 0, s, p_{\text{nom}})$

The trouble starts when

- $p \neq p_{\text{nom}}$
- $x, x', y, y \neq 0$
- dipoles are introduced

# Focusing

Magnet imperfections, misalignments, gravitation, earth magnetic field, ....

Particles will not stay on a stable circular orbit (or follow a long straight pass) => need a magnet with increasing B-field away from the centre axis

four iron pole shoes of hyperbolic contour

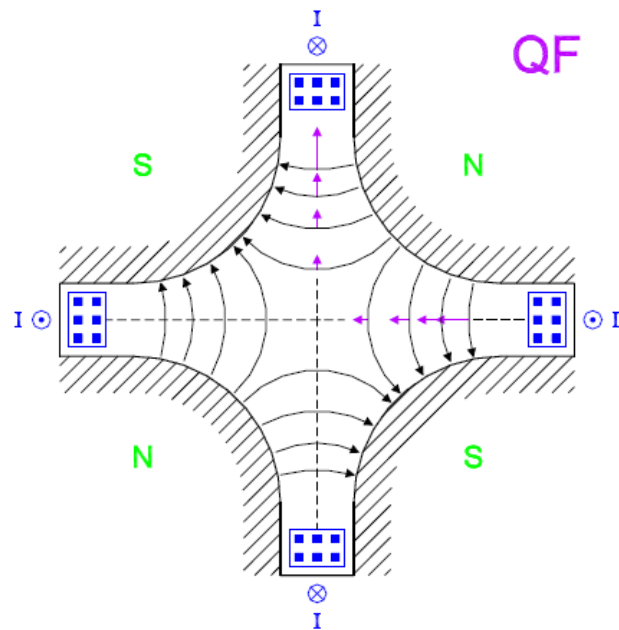

$$B_y = -g * x, \quad B_x = g * y$$

$$F_x = -g * x, \quad F_y = g * y$$

**focusing in one plane, defocusing in the other**

$$g = \frac{2\mu_0 n I}{R^2}$$

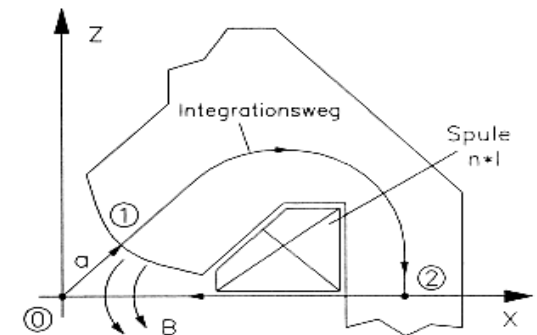

# Focusing

Net focusing effect

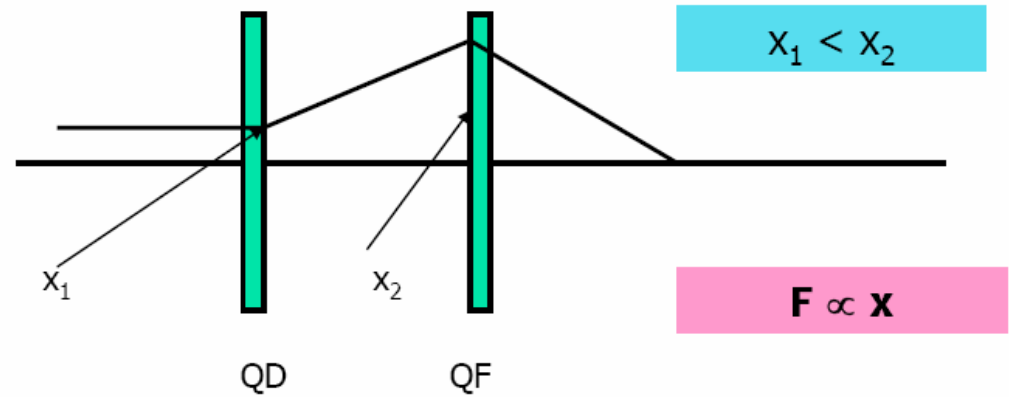

Put many quadrupoles in a row – motion is confined  
‘FODO’ structure

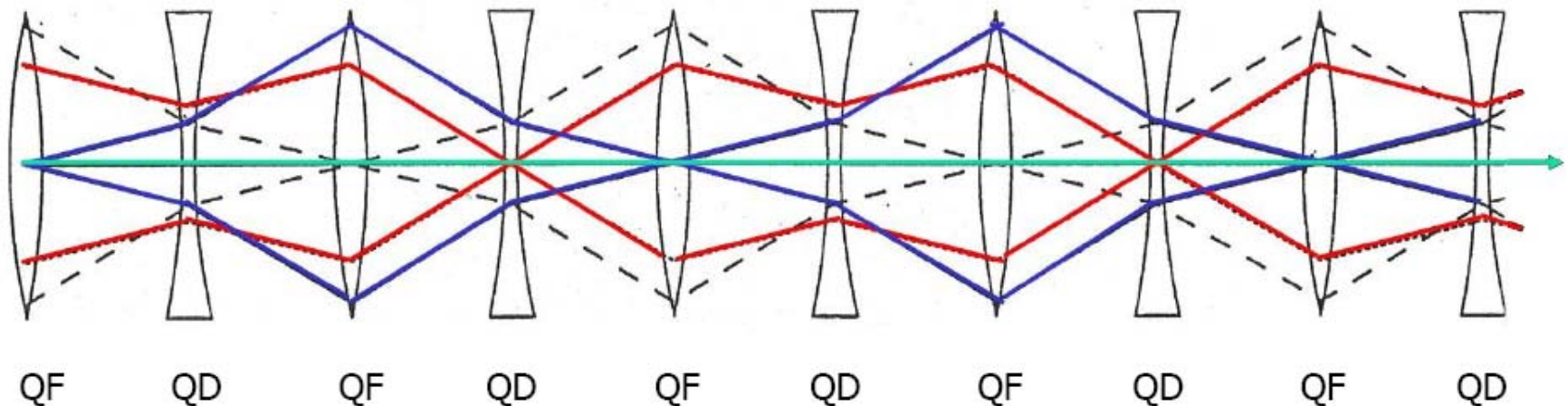

# Focusing forces and particle trajectories

normalise magnet fields to momentum (remember:  $B\rho = p/q$ )

Dipole Magnet

$$\frac{B}{p/q} = \frac{B}{B\rho} = \frac{1}{\rho}$$

Quadrupole Magnet

$$k := \frac{g}{p/q}$$

Example: HERA p Ring

Momentum:  $p = 920 \text{ GeV}/c$

Bending field:  $B = 5.5 \text{ Tesla}$

Quadrupol Gradient

$G = 110 \text{ T/m}$

→  $k = 33.64 \cdot 10^{-3} / \text{m}^2$

→  $1/\rho = 1.7 \cdot 10^{-3} / \text{m}$

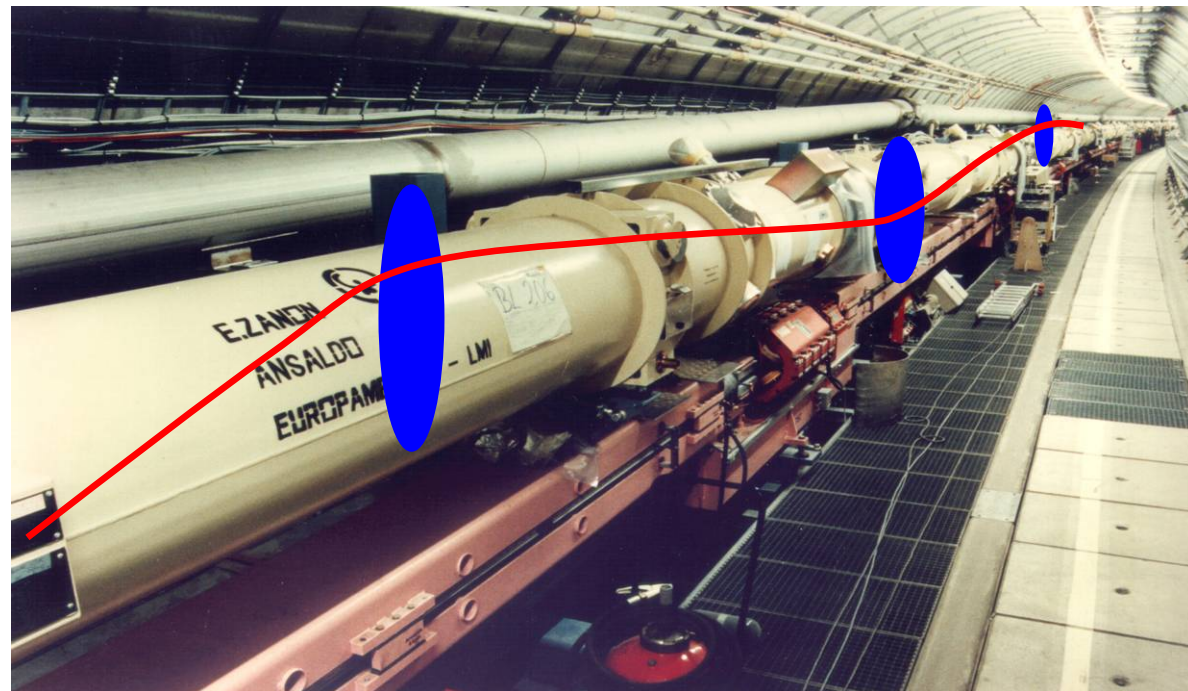

# Equation of Motion

Under the influence of the focusing and defocusing forces the differential equation of the particles trajectory can be developed:

$$x'' + k * x = 0 \quad \text{horizontal plane}$$

if we assume ....

- \* linear retrieving force
- \* constant magnetic field
- \* first order terms of displacement  $x$

... we get the general solution (hor. focusing magnet):

$$x(s) = x_0 * \cos(\sqrt{k}s) + \frac{x'_0}{\sqrt{k}} * \sin(\sqrt{k}s)$$

$$x'(s) = -x_0 \sqrt{k} * \sin(\sqrt{k}s) + x'_0 * \cos(\sqrt{k}s)$$

$x$  = distance of a single particle  
to the center of the beam

$$x' := \frac{dx}{ds}$$

*vert. plane:*  $k \Rightarrow -k$



# Matrix Formalism

Matrices of lattice elements

$$\begin{pmatrix} x \\ x' \end{pmatrix}_s = M * \begin{pmatrix} x \\ x' \end{pmatrix}_0$$

Hor. **focusing** Quadrupole

$$M_{QF} = \begin{pmatrix} \cos(\sqrt{K} * l) & \frac{1}{\sqrt{K}} \sin(\sqrt{K} * l) \\ -\sqrt{K} \sin(\sqrt{K} * l) & \cos(\sqrt{K} * l) \end{pmatrix}$$

Hor. **defocusing** Quadrupole

$$M_{QD} = \begin{pmatrix} \cosh(\sqrt{K} * l) & \frac{1}{\sqrt{K}} \sinh(\sqrt{K} * l) \\ \sqrt{K} \sinh(\sqrt{K} * l) & \cosh(\sqrt{K} * l) \end{pmatrix}$$

Drift spare

$$M_{Drift} = \begin{pmatrix} 1 & l \\ 0 & 1 \end{pmatrix}$$

formalism is only valid within one lattice element where  **$k = const$**   
in reality:  **$k = k(s)$**

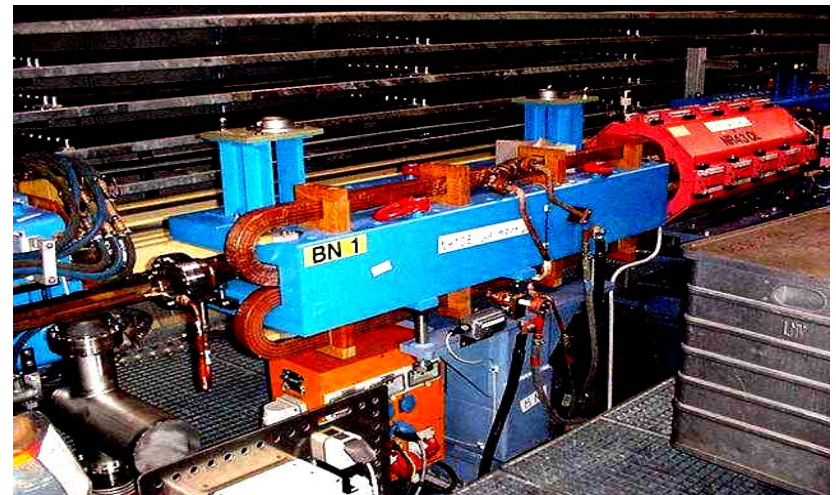

# Combination of Elements

- \* we can calculate the trajectory of a single particle within a single lattice element
- \* for any starting conditions  $x_0, x'_0$
- \* we can combine these piecewise solutions together and get the trajectory for the complete storage ring

$$M_{lattice} = M_{QF1} * M_{D1} * M_{QD} * M_{D1} * M_{QF2} \dots$$

Example:  
storage ring for beginners

Dipole magnets and QF & QD  
quadrupole lenses

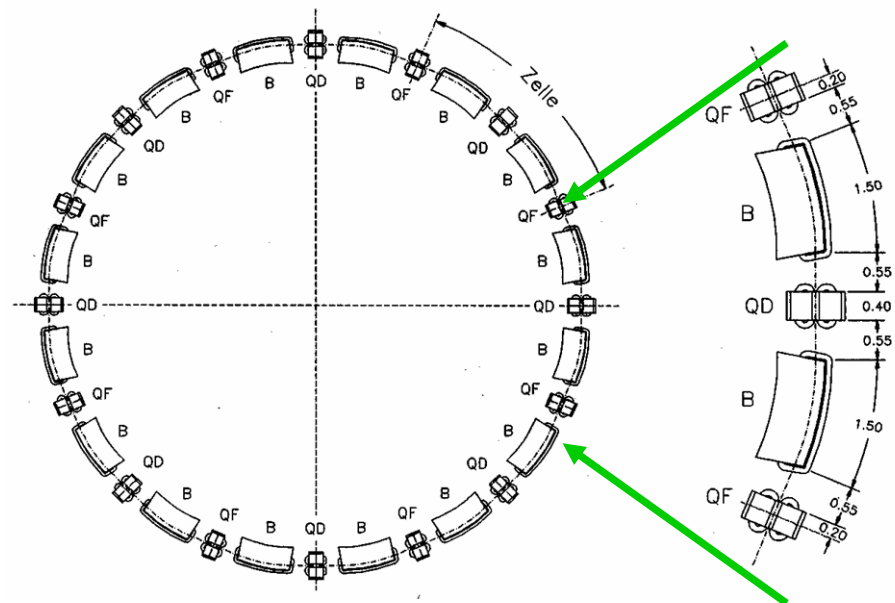

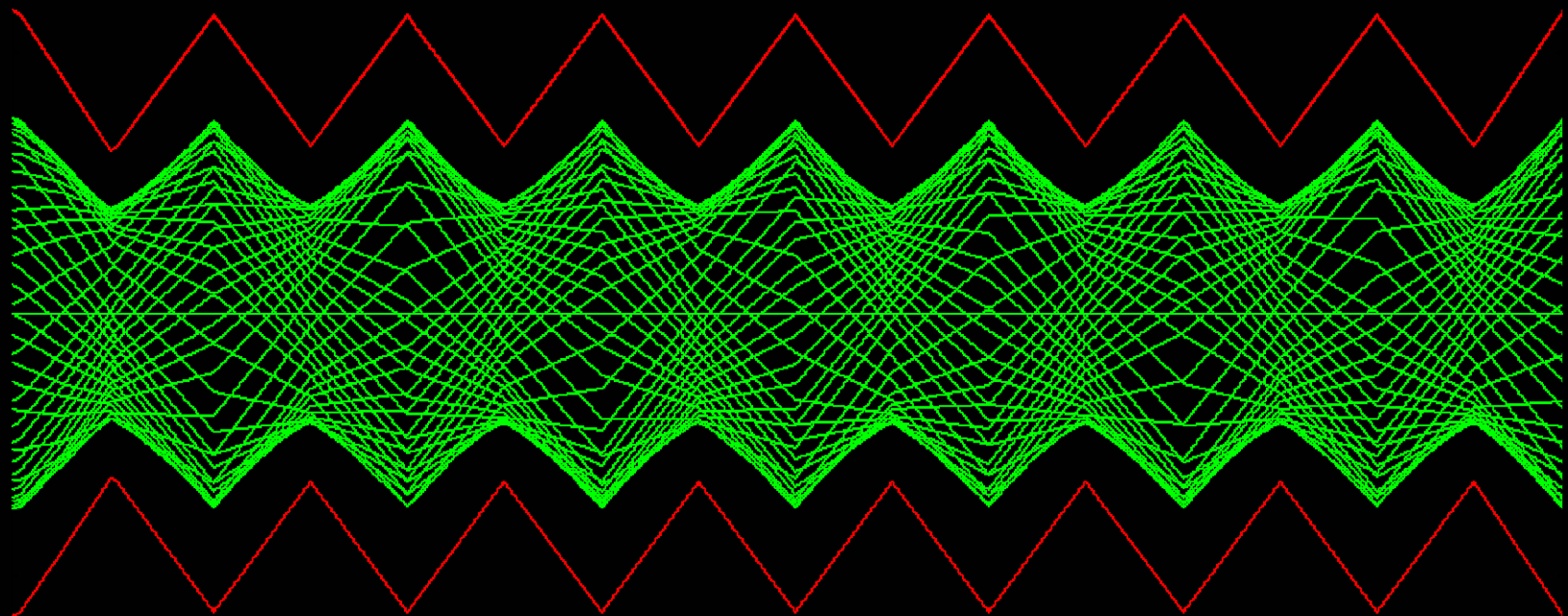

s/m ---->

# The 'Beta' Function

## equation of motion

restoring force  $\neq$  const,  
 $k(s)$  = depending on the position  $s$   
 $k(s+L) = k(s)$ , periodic function

$$x''(s) - k(s)x(s) = 0$$

we expect a kind of **quasi harmonic** oscillation: **amplitude & phase will depend on the position  $s$**  in the ring

## Solution in the form

$$x(s) = \sqrt{\varepsilon} * \sqrt{\beta(s)} * \cos(\psi(s) + \phi)$$

$\varepsilon, \Phi$  = integration constants  
determined by initial conditions

$\beta(s)$  given by **focusing properties** of the lattice  $\leftrightarrow$  quadrupoles

$\varepsilon$  **beam emittance** = **intrinsic beam parameter**,  
cannot be changed by the foc. properties.

# Transverse Phase Space

- Under linear forces, any particle moves on an ellipse in phase space
- Ellipses shear in magnets, but their area is preserved

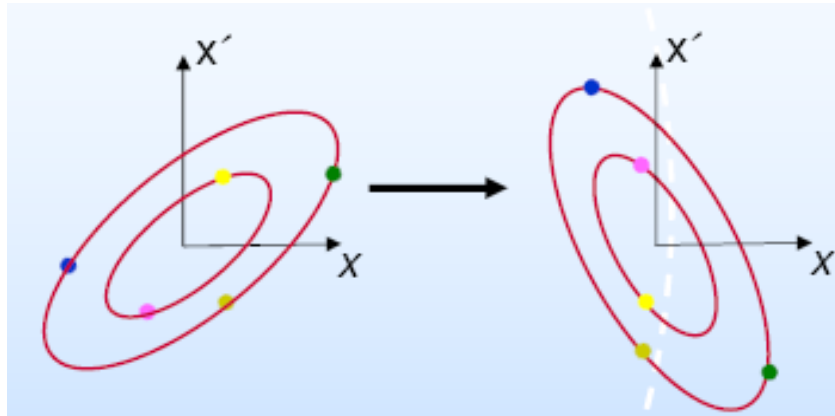

- General equation of ellipse is  $\beta x'^2 + 2\alpha x x' + \gamma x^2 = \varepsilon$
- with  $\alpha, \beta, \gamma$  functions of the distance and  $\varepsilon$  constant
- Area of ellipse is  $\pi\varepsilon$
- Statistical definitions of emittance (for nonlinear beams)
  - area covering 95% of all particles

$$\varepsilon = \sqrt{\langle x^2 \rangle \langle x'^2 \rangle - \langle x x' \rangle^2}$$

# The 'Beta' Function

$$x(s) = \sqrt{\varepsilon} * \sqrt{\beta(s)} * \cos(\psi(s) + \phi)$$

max. amplitude of all particle trajectories

$$x(s) = \sqrt{\varepsilon} * \sqrt{\beta(s)}$$

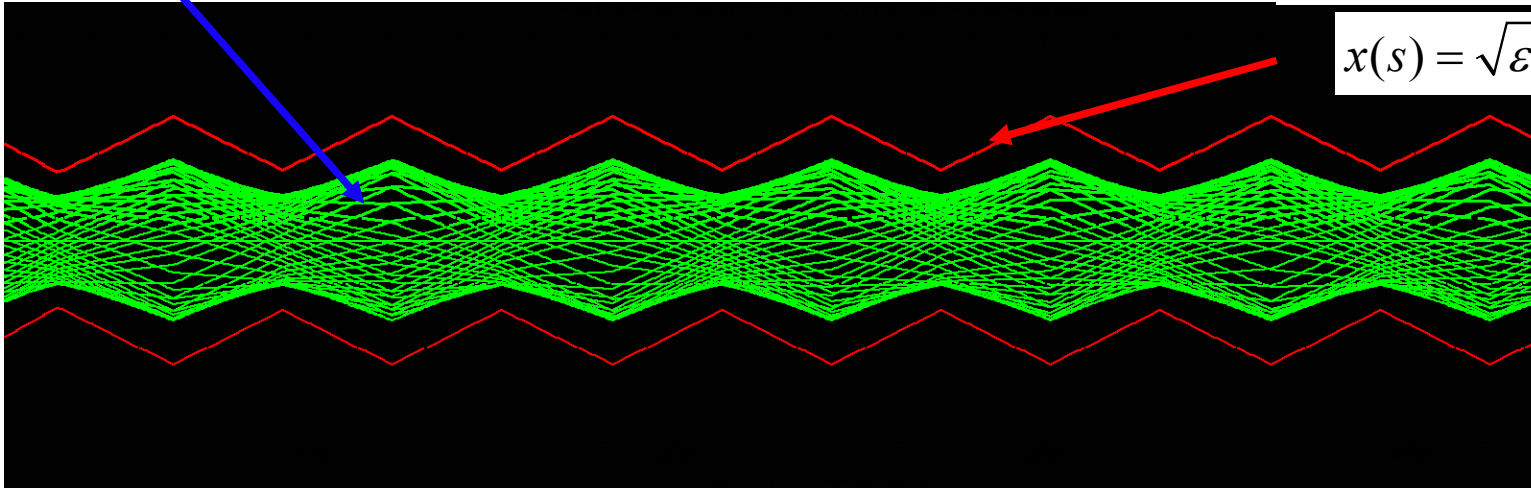

Beam Dimension:

determined by two parameters

$$\sigma = \sqrt{\varepsilon * \beta}$$

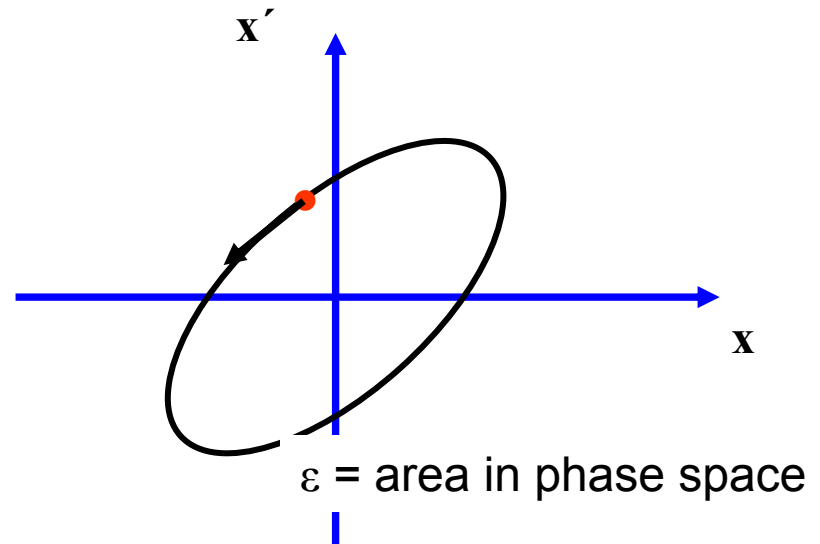

# Emittance

- Storage rings:
  - **electron storage rings**: equilibrium between quantum excitation of **synchrotron radiation** and longitudinal damping (source independent)
  - proton storage rings: source size and energy ( $\varepsilon_N = \varepsilon \times \gamma$ )
- Linacs:
  - source size and energy

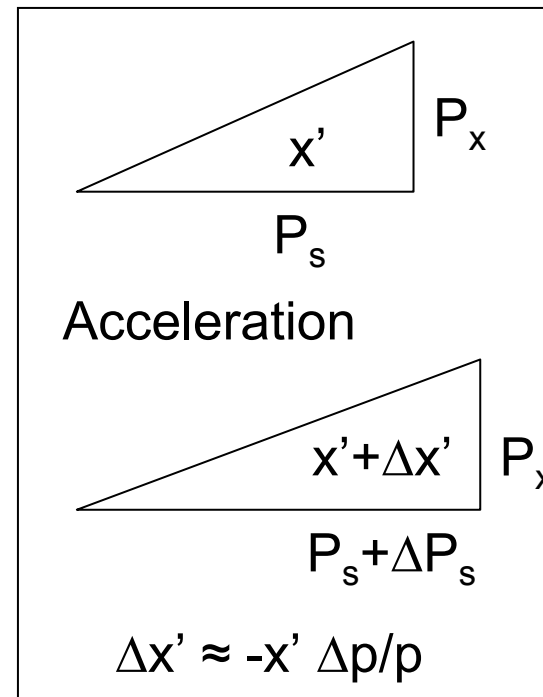
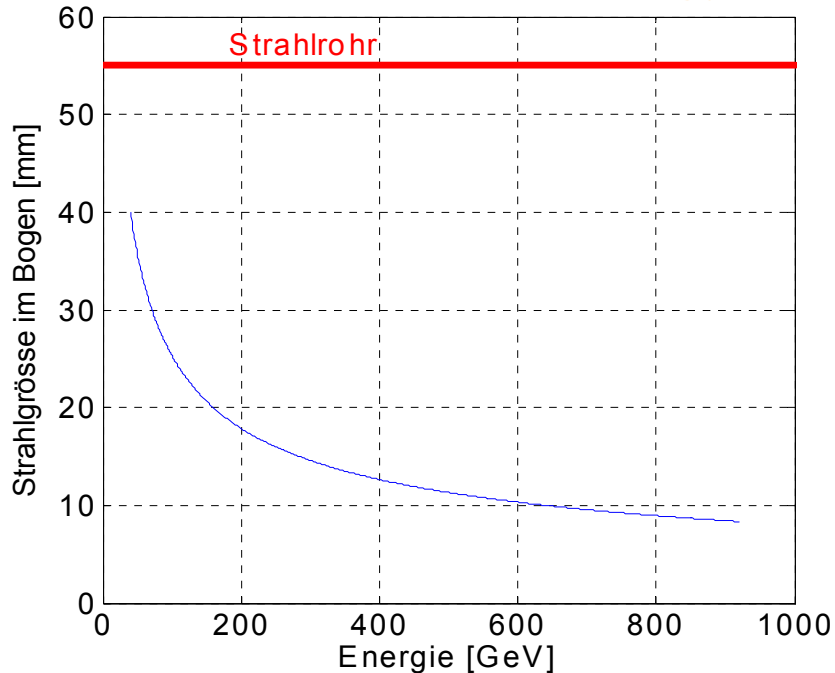

Simulation of radiation coming from

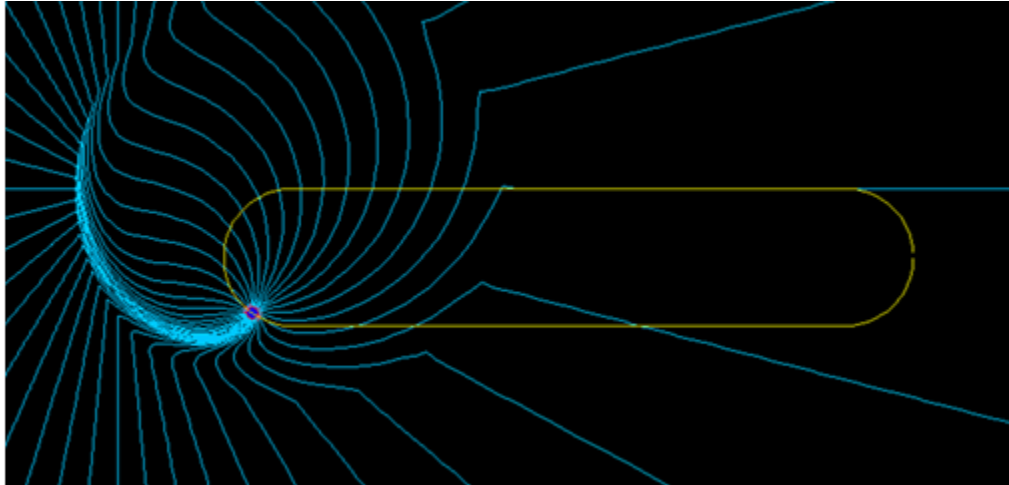

an electron traveling on a  
racetrack trajectory

an electron traveling through  
an undulator (an array of  
alternating bending magnets)

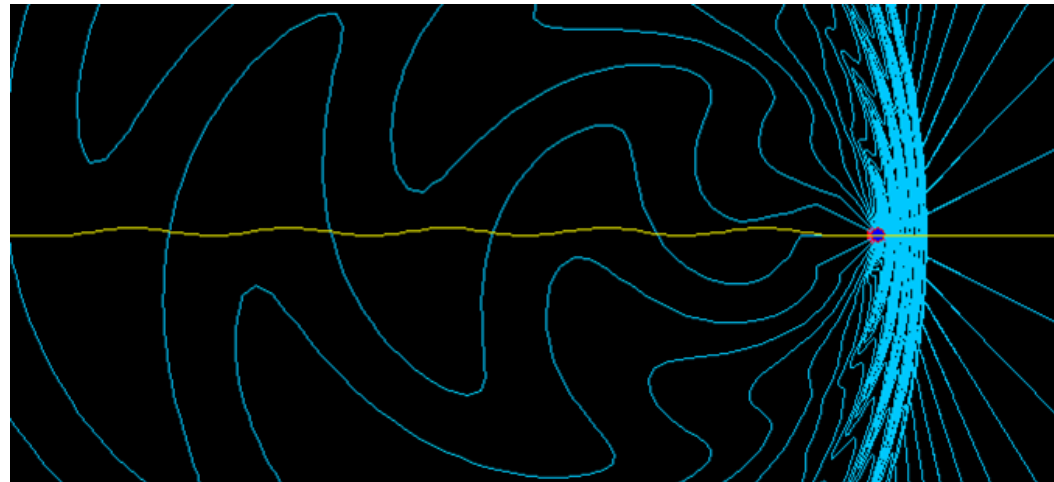



# Synchrotron Light Source PETRA III



Circumference: 2304 m

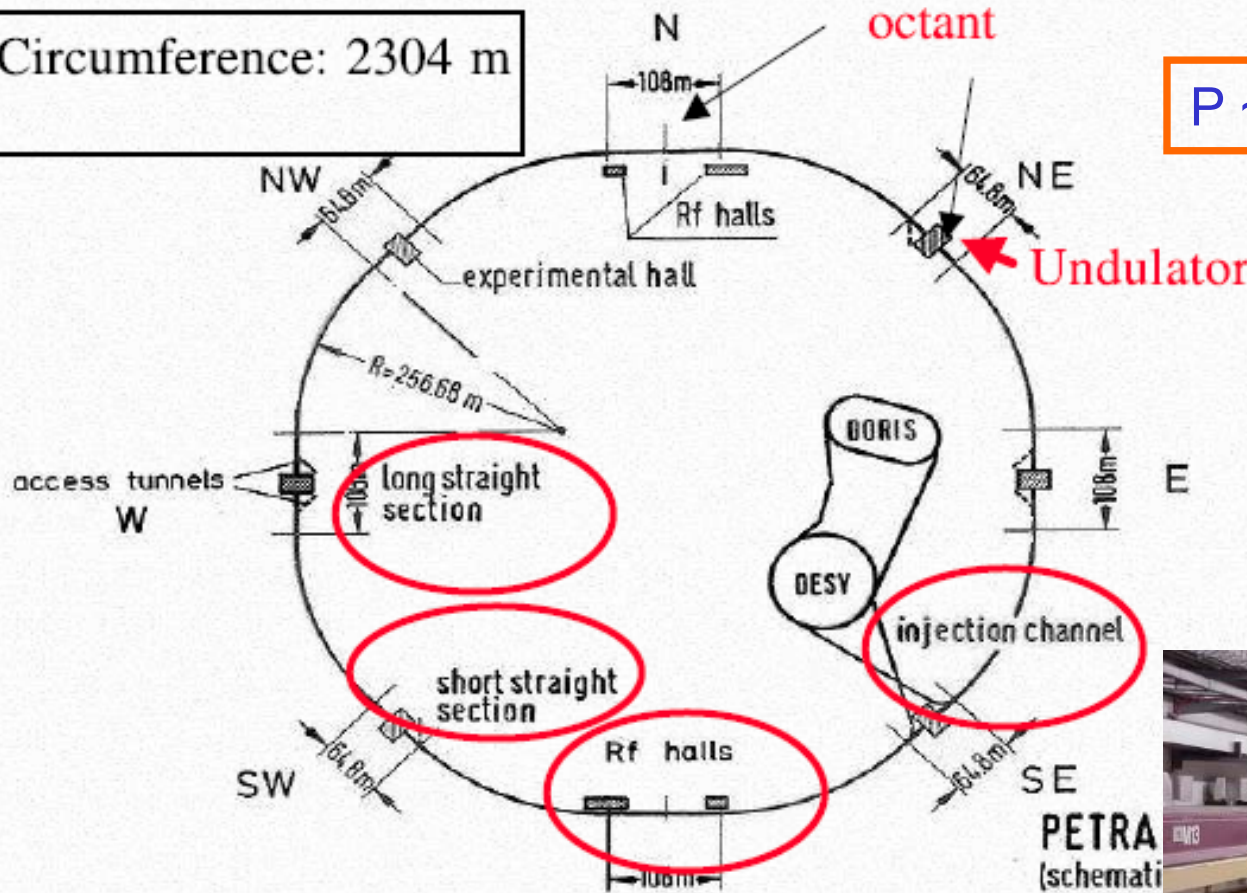

P ~ N

E = 6 GeV  
 $\epsilon = 1$  nm rad  
C = 2.3 km  
 $\rho = 200$  m  
Start in 2009



# PETRA III Optics

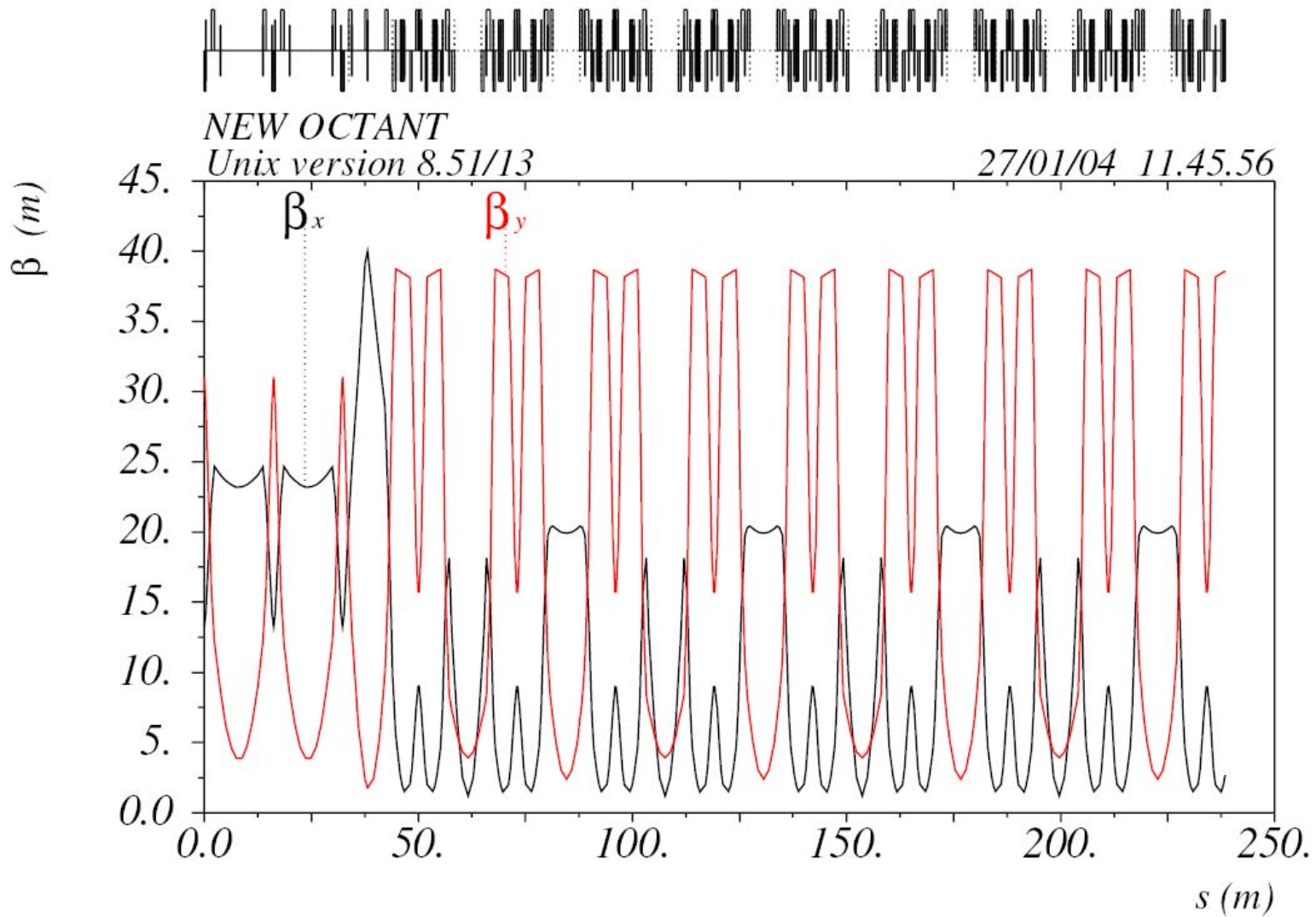

# SASE FEL

Linear Accelerator based Self Amplification of Spontaneous Emission (SASE) Free Electron Lasers (FELs) in the hard X-Ray regime ( $\sim 0.85 - 60 \text{ \AA}$ )

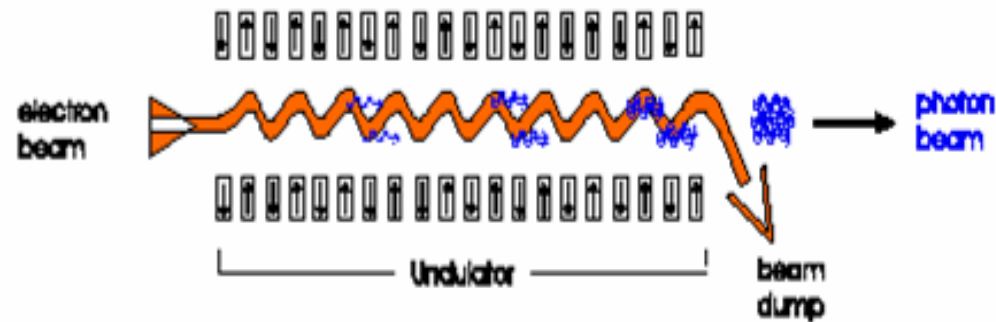

Modulation of the electron charge density with the (synchrotron radiation) field  
 $\Rightarrow$  'micro-bunching'  
 $\Rightarrow$  more and more electrons radiate in phase until saturation is reached

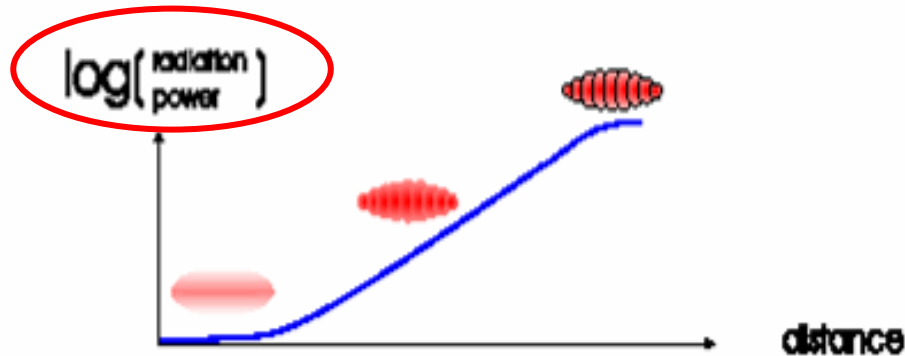

$$P \sim N^2$$

Need excellent electron beam quality:

- low emittance
- low energy spread
- extremely high charge density

# European X-Ray Free Electron Laser (XFEL)

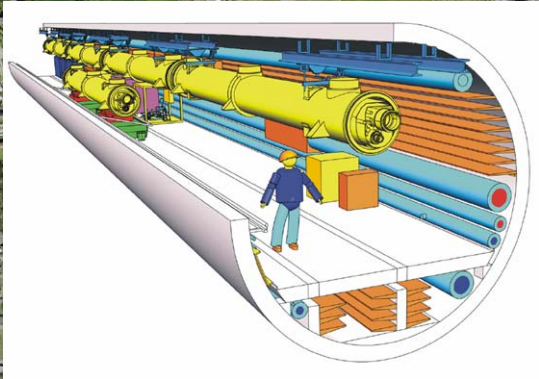
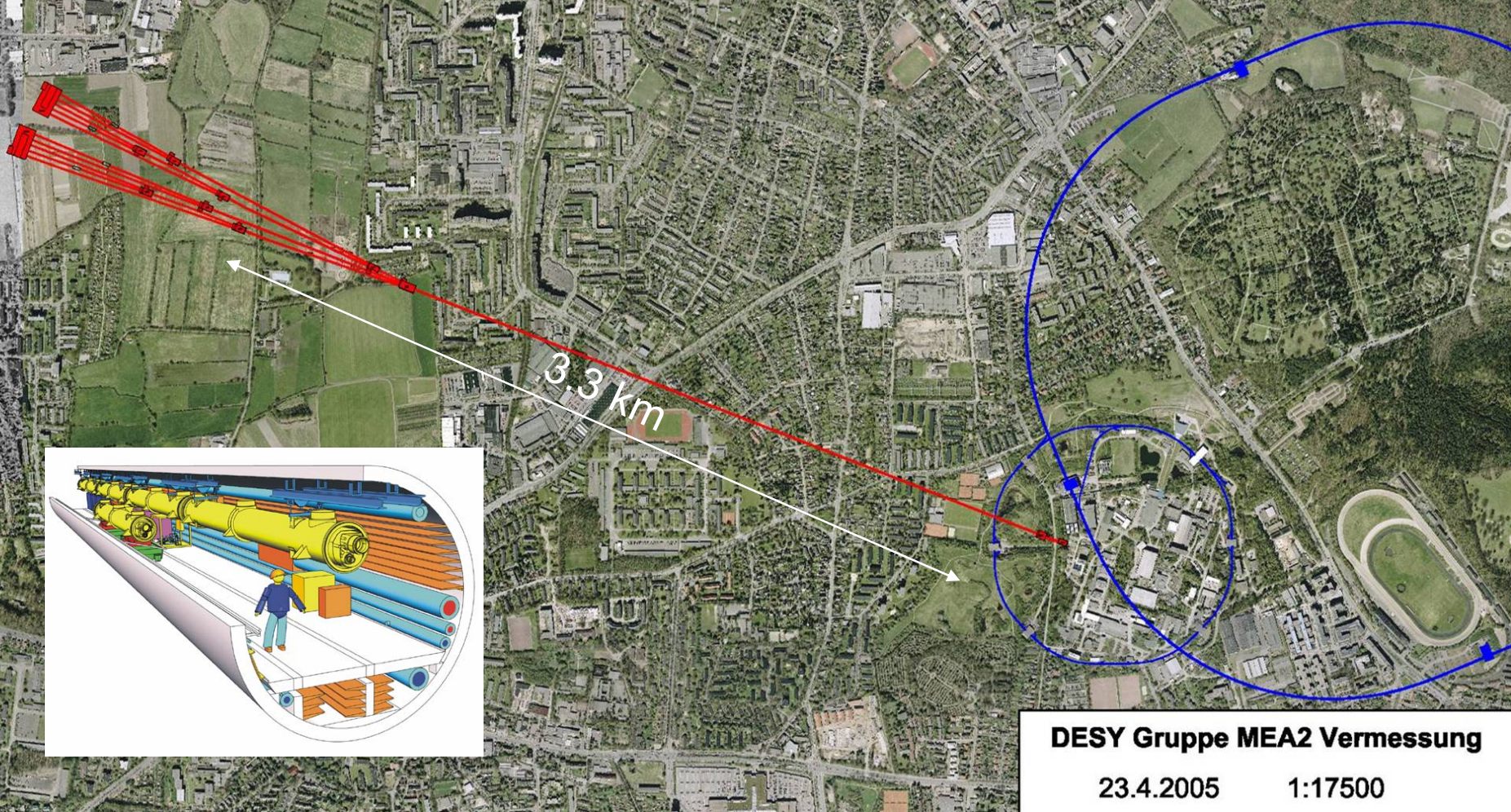
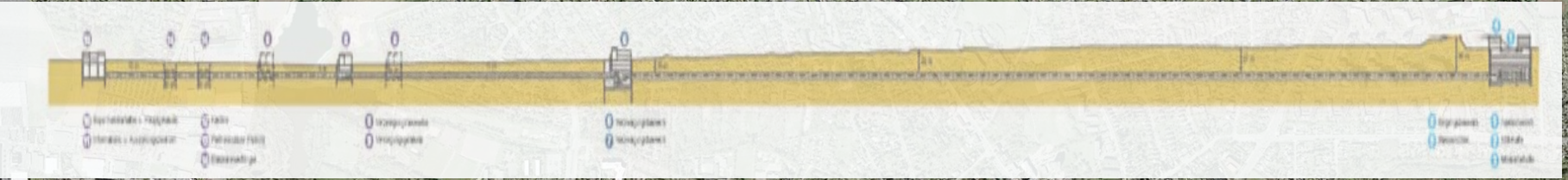

**DESY Gruppe MEA2 Vermessung**  
 23.4.2005      1:17500

# Further Issues

---

- Self Fields (particles interacting with each other)
  - repelling forces of same-charge particles limit particle density
  - higher energy helps
- Interaction with surroundings
  - Fields and image charges of particle beams interact with vacuum chamber walls, creating additional fields
  - Act back on same bunch or next bunch => Instability

# Summary

---



- Accelerator Physics is a very broad and interesting field
- Upcoming big accelerators are the LHC (this year), the ILC (2015 ?), and many FELs (European XFEL, LCLS, Spring8-XFEL ...)
- Future of the field towards more tailored and specialized devices
- Novel acceleration techniques (plasma acceleration) are on the horizon and desperately needed to advance the energy frontier

# Acknowledgments

---

- This talk based on material from
  - Bernhard Holzer (previous summer student lectures)
  - Chris Prior (CAS 2004 and 2006)
  - Daniel Brandt (CAS 2006)
- Further Reading
  - CERN Accelerator School Proceedings <http://cas.web.cern.ch/cas/>
  - E. Wilson: Introduction to Accelerators
  - S.Y. Lee: Accelerator Physics
  - H. Wiedemann: Accelerator Physics 1&2
  - K. Wille: Beschleunigerphysik
  - ....
- Accelerator Physics Programs
  - MAD-X <http://mad.home.cern.ch/mad/>
  - elegant  
[http://www.aps.anl.gov/Accelerator\\_Systems\\_Division/Operations\\_Analysis/oagPackages.shtml](http://www.aps.anl.gov/Accelerator_Systems_Division/Operations_Analysis/oagPackages.shtml)